

Planters

Implements

Disc Blades

Tillage  
Tools

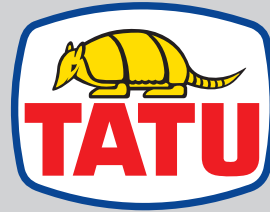

**MARCHESAN**

# INSTRUCTIONS MANUAL



**8013 GAPM-HD**

**9017 GASPM-HD**

**10020 GASPM-EHD**

# INTRODUCTION

The Heavy-Duty Hinge Offset Disc Harrows, 8013 GAPM-HD, 9017 GASPM-HD and 10020 GASPM-EHD models were developed to work in any kind of soil, with excellent performance from light to medium application. They are ideal for primary tillage or leveling after that, with excellent application in the soil tillage for annual or perennial crops.

The heavy-duty and appropriate frame structure, is made of bent steel plates joined by a good penetration and fine-finishing work welding process, with tough parts in the load concentrations areas.

All models 8013 GAPM-HD, 9017 GASPM-HD and 10020 GASPM-EHD are available with a hydraulic cylinder assembly to adjust the working angle of the harrow.

Greasable roller bearings or oil bath bearings and high quality heat treated boron steel discs are the core components that allow the equipment to have a safety and superior working life.

This manual contains the necessary information for the best harrow performance. The operator must read carefully the whole manual before operating for the first time and be aware for safety recommendations.

 **Caution: SOME PICTURES MAY SHOW SHIELDS OR LOCK DEVICES REMOVED FOR PURPOSES OF CLARITY. NEVER OPERATE THIS EQUIPMENT WITHOUT ALL SAFETY DEVICES IN PLACE AND IN GOOD OPERATIONAL CONDITION.**

The operator must be familiar with the implement, tractor operation and all associated safety practices before operating them. Proper operation of the implement, as detailed in this manual, will help ensure years of safe and satisfactory use of the disc harrow.

This manual is provided to give you the necessary operating and maintenance instructions for keeping your harrow in top operating condition. Please read this manual thoroughly. It should be remaining with the implement when you trade or sell it. In case your manual should become lost or destroyed, please contact your dealer to get a new copy.

For further information or in the event of any technical assistance issue, please contact your dealer who, along with the Technical Assistance Department of the factory guarantees the proper functioning of your TATU Disc Harrow.

 **Important: ALL REFERENCES MADE TO RIGHT, LEFT, FRONT, REAR, TOP OR BOTTOM IS AS VIEWED FACING THE DIRECTION OF TRAVEL WITH IMPLEMENT PROPERLY ATTACHED TO TRACTOR.**



# INDEX

FOR THE OWNER .....	3
FOR THE OPERATOR .....	4 to 7
Operation Safety .....	4
Transport Safety .....	6
Safety Recommendation .....	7
DESCRIPTION & SPECIFICATIONS .....	8 to 11
8013 GAPM-HD - Technical Specifications .....	8
9017 GASPM-HD - Technical Specifications .....	9
10020 GASPM-EHD - Technical Specifications .....	10
Components .....	11
PREPARATION FOR USE .....	12 to 23
General Instructions .....	12
How to Use the Wrenches .....	13
Mounting Main Gangs .....	13
Disc Gangs Assembly .....	16
Mounting of Disc Gangs on Gang Carriers .....	18
Gang Carriers Joint .....	19
Scrapers Assembly .....	19
Working Angle Adjusting System .....	20
Hydraulic Cylinder Assembly .....	21
Mounting the Drawbar Assembly .....	22
Mounting the Hydraulic System Valve .....	23
Mounting the Shock Absorber .....	23
ADJUSTMENT & OPERATION .....	24 to 32
Tractor Set-up .....	24
Harrow Set-up .....	25
Depth of Cut .....	27
Drawbar Vertical Adjustment .....	29
Drawbar Lateral Adjustment - Offsetting .....	29
How to Start Discing .....	30
Maneuver Directions .....	31
Operation - Main Instructions .....	32
MAINTENANCE .....	33 to 35
Lubrication .....	33
Long Term Storage .....	35
IMPORTANT DATA .....	36 and 37
How to Calculate Theoretical Hourly Performance .....	36
Theoretical Average Performance Table .....	37
IMPORTANT .....	38

# FOR THE OWNER

CONGRATULATIONS! You have invested in a TATU product from Marchesan S/A, a Brazilian based company established in 1946. Marchesan S/A is the leading manufacturer of Farm Equipment in the Southern Hemisphere, TATU quality products are exported to many countries in Latin America, North America and other regions where subtropical farming technology is required.

The original purchaser of any TATU product is entitled to the following:

- Certificate of guarantee;
- Instruction manual;
- Technical explanation by the retailer.

It is the responsibility of the owner to check the condition of the product on receipt of it and to check the terms of guarantee.

Special attention should be paid to the safety precautions, to the product operation and maintenance guidelines.

The instructions in this manual indicate the optimum usage and should ensure maximum results and increase the life of this product and it should be read by all persons operating and maintaining this equipment.

**Important:** **ONLY THOSE PERSONS WHO ARE FULLY TRAINED IN THE USE OF THE TRACTOR AND ATTACHMENTS SHOULD TRANSPORT OR OPERATE THEM. MARCHESAN IS NOT RESPONSIBLE FOR ANY DAMAGE ARISING FROM INCORRECT OR IMPROPER TRANSPORTATION, USE OR STORAGE OF ITS PRODUCTS, WHETHER BY NEGLIGENCE AND/OR INEXPERIENCE OF ANY PERSON. MARCHESAN IS NOT RESPONSIBLE FOR DAMAGE CAUSED DUE TO UNFORESEEN CIRCUMSTANCES OR USAGE OTHER THAN FOR WHICH THE EQUIPMENT WAS INTENDED.**



## General Information

- The **right hand and left hand** sides of the disc harrow are determine by facing in the direction the implement will travel when moving forward.

- To obtain parts or technical assistance it is necessary to provide the details displayed on the identification plate which is located on the mainframe.

MODELO		DATA	
SÉRIE/Nº		PESO	
MARCHESAN IMPLEMENTOS E MÁQUINAS AGRÍCOLAS "TATU" S/A			
AV. MARCHESAN, 1979			
MATÃO - SP - BRASIL			
FONE: (16) 3382-8282			
FAX: (16) 3382-3607			
CNPJ: 52.311.289/0001-63			
Inscr. Est. 441.000.151.114			
		Plantadeiras	
		Implementos	
		Discos	
		Ferramentas	
		Agrícolas	

**Note: ALTERATIONS AND MODIFICATIONS OF THE PRODUCT WHICH ARE DONE WITHOUT THE EXPRESS PERMISSON OF MARCHESAN S/A, AS WELL AS THE USE OF NON-ORIGINAL REPLACEMENT PARTS, WILL VOID THE GUARANTEE.**

# FOR THE OPERATOR



Dear User !  
Respect the Ecology. Do not throw the trash away. This gesture of goodwill helps to protect our Environment.



Disposing fluids onto the ground directly affects the environment. Educate yourself about the correct way to dispose of these pollutants by taking them to recycling centers.

## OPERATION SAFETY



- ONLY WITH A COMPLETE CO-OPERATION OF EQUIPMENT OPERATOR THE ACCIDENTS CAN BE AVOIDED.
- THIS SYMBOL IS A WARNING DEVICE WHICH SHOULD BE KEPT IN A CLEAN AND VISIBLE PLACE, WHEN TRANSPORTING THE IMPLEMENT DURING THE DAY OR NIGHT. USE ACCESSORY LIGHT AND OTHER DEVICES IN ORDER TO GIVE ADEQUATE WARNING TO OTHER VEHICLES.

The TATU disk harrows are easy to operate, therefore some basic and indispensable cares are required on their handling.

Have always on mind that safety requires constant attention, observation and prudence during the operation, transport, maintenance and storage of the equipment.



- Important:**
- PRACTICE ALL USUAL AND CUSTOMARY SAFE WORKING PRECAUTIONS AND ABOVE ALL - REMEMBER SAFETY IS UP TO YOU. ONLY YOU CAN PREVENT SERIOUS INJURY OR DEATH FROM UNSAFE PRACTICES.
  - IF YOU DO NOT UNDERSTAND ANY PART OF THIS MANUAL AND NEED ASSISTANCE, CONTACT YOUR AUTHORIZED DEALER.



Read the Instruction Manual. Failure to read the Instruction Manual is considered a misuse of this equipment.

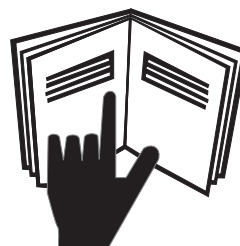

Become familiar with all the equipment's controls and all the caution, warning and danger decals affixed to the equipment before attempting to start or operate.

# FOR THE OPERATOR



Never use your hands to check hydraulic leaks. Escaping hydraulic oil under pressure may have sufficient force to penetrate the skin causing personal injury.



Never attempt to change the adjustments, clean or lubricate the implement when in movement.



Be careful when moving around steep graders to avoid overturn.



Be careful with the use of fertilizer or chemicals. These products in contact with skin may cause personal injury to the body.



Keep the entrances and places accessible to work, clean and free of the oil and grease to prevent accidents.



Never transport the implement on rough roads during the night. When operating, avoid to make sharp turns that may cause tire contact with the implement.



Never allow riders on the tractor or implement unless an additional seat is available.



Use extreme caution when circulating with the implement under electrical power lines, any contact may result in severe shock, injury or death.



In order to protect yourself always wear adequate clothes and shoes during operation or maintenance.

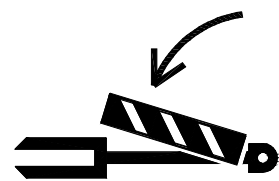

Always use the cylinder transport locks when transporting the implements.

# FOR THE OPERATOR

## TRANSPORT SAFETY

### Transporting on Roads or Highways



- Comply with state and local laws governing highway safety and movement of farm machinery on public roads.
- The use of flashing amber lights is acceptable in most localities. However, some localities prohibit their use. Local laws should be checked for all lighting and marking requirements.
- At all times, when driving the tractor and equipment on the road or highway under 20mph (32kph) use flashing amber warning lights and a slow moving vehicle (SMV) identification emblem. Do not exceed 20mph (32kph). Reduce speed on rough roads and surfaces.
- Plan your route to avoid heavy traffic.
- Always install transport locks, pins or brackets before transporting.
- Do not drink and drive.
- Be a safe and courteous driver. Always yield to oncoming traffic in all situations, including narrow bridges, intersections, etc. Watch for traffic when operating near or crossing roadways.
- Turn curves, go up or down hills only at a low speed and at a gradual steering angle. Slow down on rough or uneven surface. Always check tractor manual for proper use on slopes.
- Use extreme care and maintain minimum ground when operating close to ditches or fences. Be careful when turning sharp corners.

### Tow Loads Safely



- Stopping distance increases with speed and weight of towed loads, and on slopes. Towed loads with or without brakes that are too heavy for the tractor or are towed too fast can cause loss of control. Consider the total weight of the equipment and its load.
- Observe these recommended maximum road speeds, or local speed limits which may be lower.
- If towed equipment does not have brakes, do not travel more than 32.0 km/h (20.0 mph) and do not tow loads more than 1.5 times the tractor weight.
- If towed equipment has brakes, do not travel more than 40.0 km/h (25.0 mph) and do not tow loads more than 4.5 times the tractor weight.
- Ensure the load does not exceed the recommended weight ratio. Add ballast to recommended maximum for tractor, lighten the load, or get a heavier towing unit. The tractor must be heavy and powerful enough with adequate braking power for the towed load. Use additional caution when towing loads under adverse surface conditions, when turning, and on inclines.

**Caution:** DISC HARROW WIDTH - DEPENDING ON SIZE, THE DISK HARROW MAY BE WIDER THAN A ROAD LANE.  
WHEN TRANSPORTING ON PUBLIC ROADS, BEWARE OF TRAFFIC.



# FOR THE OPERATOR

## Hauling the Equipment Over Long Distances



- Use adequate ramps to load and unload the equipment. Do not attempt to load on a slope as serious accidents could happen.
- When loading is done with a crane, attach the hoist at the appropriate points.
- Ensure that the equipment is adequately secured.
- Use sufficient fastenings (ropes, chains, cord etc.) to immobilize the equipment during transport.
- Check the condition of the cargo after the first 5-7 miles (8-11 kilometres) of the journey, then at 50-70 miles (80-110 kilometres) intervals check to ensure that the fastenings have not become loose. Check the load more frequently on bumpy roads.
- Always be alert. Pay attention to headroom clearance, especially when passing underneath electricity cables, viaducts etc.
- Always check applicable laws regarding height and width limits for loads. If necessary, use flags, lights and reflectors to alert other motorists.

## SAFETY RECOMMENDATION



- During the operation or transport do not allow riders on the tractor or harrow. Serious personal injuries may result from falling in the path of harrow while in operation or transport.
- Never allow children playing near or over the harrow, even on operation, transportation or storing.
- Get a full knowledge of the area before starting the field operation. Delimit the danger places or the obstacles.
- Work and transport with suitable speed according to the local conditions.
- Use individual equipments for your own protection. Wear clothes and adequate shoes. Avoid large or loosen clothes that may twine on the movable parts.
- Be careful when attaching the harrow to the tractor. Hands or fingers may be injured when caught between the hitch and the tractor.
- Wear protection gloves when working near the discs.
- When putting the harrow in transport position observe if there are not people or animals around.
- Never attempt to change the adjustment, clean or lubricate the harrow when in movement.
- Shut the tractor off before leaving the tractor's seat.
- Only operate the harrow with tractor of appropriate power.
- Check attentively the transport width in narrow places.
- When disconnecting the disc harrow move it to a level area; preferably a hard surface, on the field or at the warehouse.



# DESCRIPTION & SPECIFICATIONS

## 8013 GAPM-HD - Technical Specifications

Disc Blade Spacing ..... 340 mm (13.3/8")  
 Disc Blade Dimension ..... Ø 32", Ø 34" or Ø 36"  
 Number of Discs Blade ..... 14, 16, 20, 24 and 28  
 Disc Type ..... All Notched on Both Front and Rear Gangs  
 Bearing Assy's { Lenght ..... 330 mm (13")  
                           { Type ..... Greasable or Oilbath  
 Spacer Spools { Lenght ..... 330 mm (13")  
                           { Type ..... Casting  
 Axle Diameter ..... 63.5 mm (2.1/2")  
 Depth of Cut ..... 120 to 260 mm (4.3/4" to 10.1/4")  
 Type of Hitch ..... Drawbar  
 Working Speed ..... 5.0 to 7.0 Km/h

Model	No. of Disc Blades	Working Width		Net Weight*		Tractor (hp) Required
		ft. in.	(mm)	lbs.	(kg)	
<b>8013 GAPM HD</b>	14	7'3"	2,210	9,031	4,096	180 - 200
	16	8'3"	2,550	10,280	4,662	200 - 220
	20	10'7"	3,230	10,950	4,966	220 - 240
	24	12'10"	3,910	13,520	6,132	260 - 280
	28	15'0"	4,580	15,830	7,180	310 - 330

\* THE WEIGHT WAS QUOTED WITH 32" DIAM. AND 9.00 MM THICKNESS DISC BLADES.

# DESCRIPTION & SPECIFICATIONS

## 9017 GASPM-HD - Technical Specifications

Disc Blade Spacing .....	440 mm (17.5/16")	
Disc Blade Dimension .....	Ø 34", Ø 36", Ø 38" or Ø 40"	
Number of Disc Blades .....	10, 12, 16 and 20	
Disc Blade Type .....	All Notched on Both Front and Rear Gangs	
Bearing Assy's {	Lenght .....	430 mm (16.7/8")
	Type .....	Greasable or Oilbath
Spacer Spools {	Lenght .....	430 mm (16.7/8")
	Type .....	Casting
Axle Diameter .....	63.5 mm (2.1/2")	
Depth of Cut .....	120 to 260 mm (4.3/4" to 10.1/4")	
Type of Hitch .....	Drawbar	
Working Speed .....	5.0 to 7.0 Km/h	

Model	No. of Disc Blades	Working Width		Net Weight*		Tractor (hp) Required
		ft. in.	(mm)	lbs.	(kg)	
<b>9017 GASPM HD</b>	10	5'10"	1,800	6,733	3,054	130 - 140
	12	7'3"	2,200	7,500	3,402	145 - 155
	16	10'2"	3,100	10,553	4,787	205 - 220
	20	13'1"	4,000	13,198	5,986	260 - 280

**\* THE WEIGHT WAS QUOTED WITH 36" DIAM. AND 12.00 MM THICKNESS DISC BLADES.**

# DESCRIPTION & SPECIFICATIONS

## 10020 GASPM-EHD - Technical Specifications

Disc Blade Spacing .....508 mm (20")  
 Disc Blade Dimension ..... Ø 34", Ø 36", Ø 38" or Ø 40"  
 Number of Disc Blades ..... 10, 12, 16 and 20  
 Disc Blade Type ..... All Notched on Both Front and Rear Gangs  
 Bearing Assy's { Length ..... 495 mm (19.1/2")  
                           { Type ..... Greasable or Oilbath  
 Spacer Spools { Length ..... 495 mm (19.1/2")  
                           { Type ..... Heavy Steel  
 Axle Diameter ..... 63.5 mm (2.1/2")  
 Depth of Cut ..... 120 to 280 mm (4.3/4" to 11")  
 Type of Hitch ..... Drawbar  
 Working Speed ..... 5.0 to 7.0 Km/h

Model	No. of Disc Blades	Working Width		Net Weight*		Tractor (hp) Required
		ft. in.	(mm)	lbs.	(kg)	
<b>10020 GASPM EHD</b>	10	8'0"	2,400	9,347	4,240	180 - 200
	12	9'6"	2,900	10,286	4,665	200 - 220
	16	12'5"	3,800	13,290	6,028	260 - 280
	20	14'8"	4,500	15,474	7,019	300 - 320

**\* THE WEIGHT WAS QUOTED WITH 36" DIAM. AND 12.00 MM THICKNESS DISC BLADES.**

# DESCRIPTION & SPECIFICATIONS

## COMPONENTS

- 01 - Front Frame - Gang Carrier
- 02 - Rear Frame - Gang Carrier
- 03 - Frames Assembly Joint
- 04 - Hydraulic Cylinder
- 05 - Adjusting Working Angle System
- 06 - Hydraulic Hoses
- 07 - Hose Holder
- 08 - Drawbar Assembly
- 09 - Transport Lock System
- 10 - Jackstand
- 11 - Wrenches Support
- 12 - Hitch
- 13 - Rod Stops

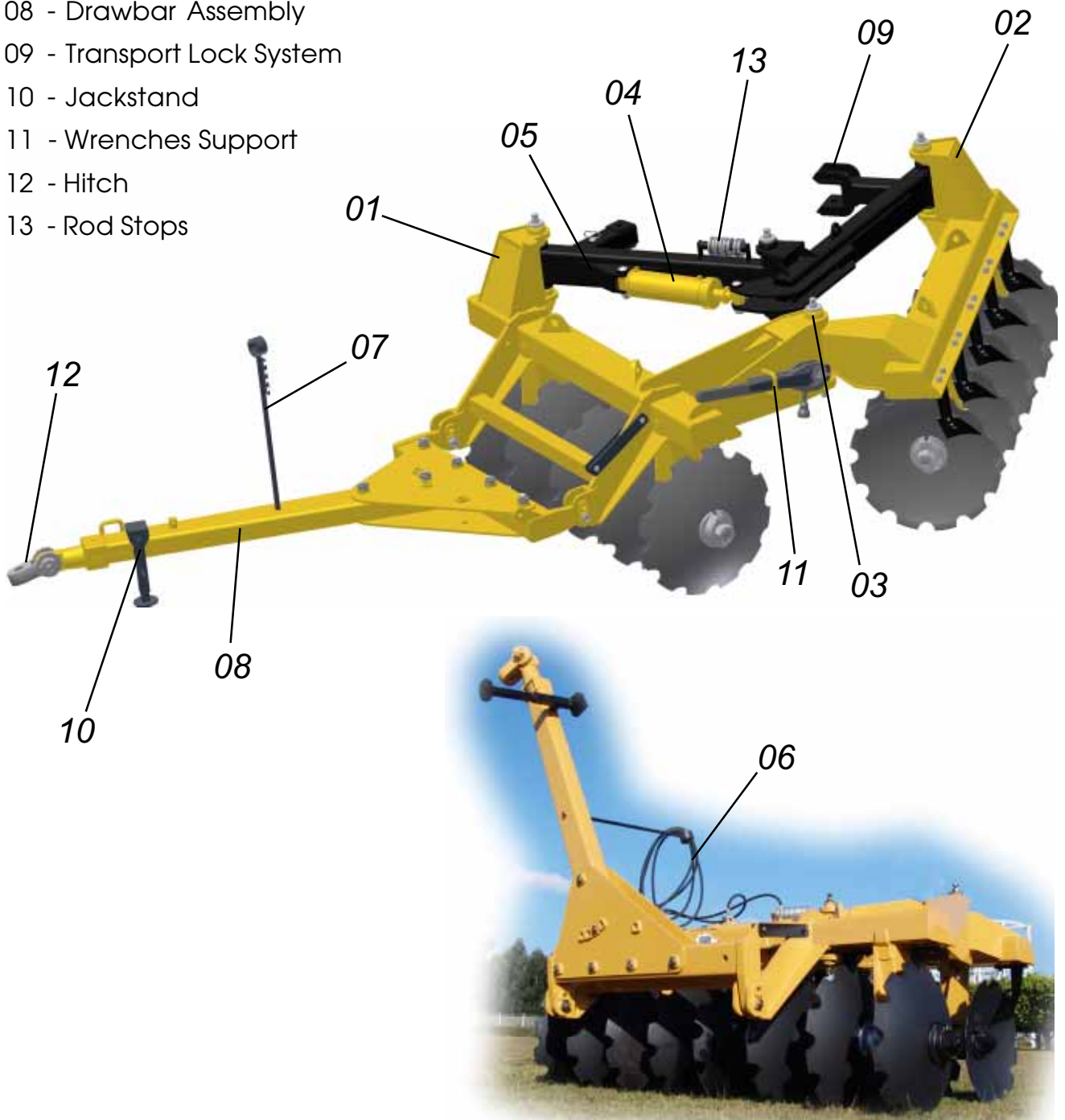

# PREPARATION FOR USE

## GENERAL INSTRUCTIONS



**Caution: THE FOLLOWING SAFETY PRECAUTIONS SHOULD BE THOROUGHLY UNDERSTOOD BEFORE ATTEMPTING MACHINE ASSEMBLY.**

1. Wear personal protective equipment such as, but not limited to protection for eyes, ears, feet, hands, lungs and head when assembling the equipment. Do not wear loose clothing or jewelry that may catch on equipment moving parts.
2. Do not lift heavy parts or assemblies. Use crane, jack, tackle, fork trucks or other mechanical devices.
3. Select an area for assembly that is clean and free of any debris which might cause persons working on the assembly to trip.
4. Arrange parts to be assembled neatly in the work area and have tools or other mechanical assisting devices in easy reach.
5. Inspect all parts and assemblies thoroughly and remove any sharp edges, grease, oil or dirt which might cause pieces to slip when handling.
6. Preview the assembly instructions in your operator's manual before proceeding further.
7. If the assembly instructions call for parts or assemblies to be blocked up, use only blocking material that is in good condition and is capable of handling the weight of the assembly to be blocked. Also, insure that the blocking material is on a clean, dry surface.
8. Never put hands or any other part of body under blocked up assemblies if at all possible.
9. Always wear goggles or safety glasses when hammering, grinding, or drilling metal parts.
10. If the assembly calls for welding or cutting, be sure that there are no flammable materials close at hand and that bystanders have taken necessary precautions.

**Note: AFTER COMPLETING ANY ASSEMBLY STEP, THOROUGHLY READ THE NEXT STEP IN THE ASSEMBLY INSTRUCTIONS BEFORE PROCEEDING WITH THAT STEP.**

11. After completing assembly, thoroughly inspect the machine to be sure that all nuts, bolts, hydraulic fittings or any other fastened assemblies have been thoroughly tightened.
12. After completing assembly, be sure that all safety locking devices or guards are in place.
13. Before operating the equipment, thoroughly read the operation section of this manual.
14. Before operating the equipment, read the maintenance section of this manual to be sure that any parts requiring lubrication such as gearboxes are full to avoid any possible damage.

**Note: BEFORE OPERATING THE EQUIPMENT, IF YOU HAVE ANY QUESTIONS REGARDING THE PROPER ASSEMBLY OR OPERATION, CONTACT YOUR AUTHORIZED DEALER OR REPRESENTATIVE.**

# PREPARATION FOR USE

First of all, choose a clean and flat surface. Split the parts in groups to make it easier to pick them up and check the quantities against the packing list.

## HOW TO USE THE WRENCHES

- Wrenches (A) are used to tighten nuts of the disc gang carriers, one to hold the axle nut in one side, while tighten the other onto the opposite side, avoiding the axle to turn around.

- Wrench (B) is used to tighten bolts and nuts of the bearing assemblies.

- Wrench (C) is used to tighten bolts and nuts of the drawbar assembly.

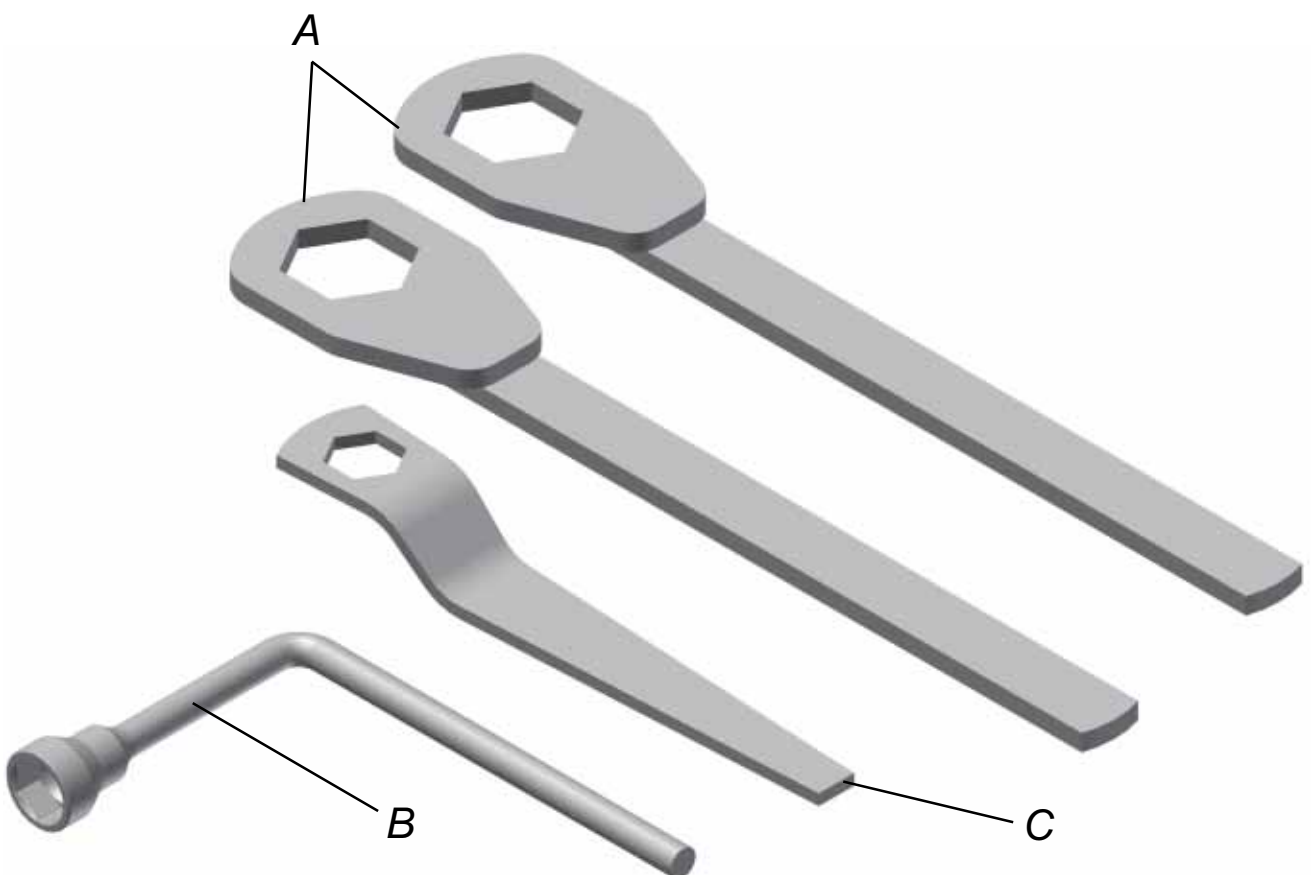

**Attention:** DISC BLADES ARE SHARP AND COULD CAUSE INJURIES AS CUT HANDS, FEET, ETC. WEAR GLOVES WHEN HANDLING DISC GANGS TO THE MAIFRAME.



## MOUNTING MAIN GANGS

Be sure that you have the correct frames for the disc harrow being assembled. Check the correct positioning for the bearing assemblies and spacers as shown on the following pages:

# PREPARATION FOR USE

## Illustration to Assemble Bearings and Spacers

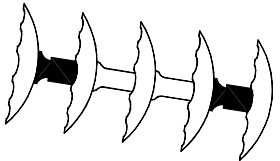
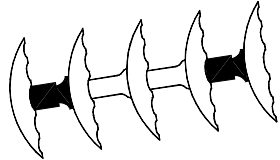
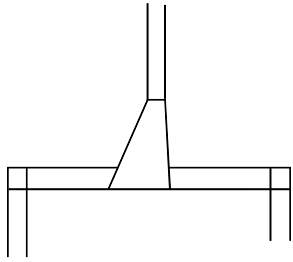

9017 GASPM-HD and  
10020 GASPM-EHD 10 discs  
04 bearings + 04 spacers

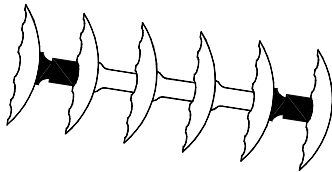
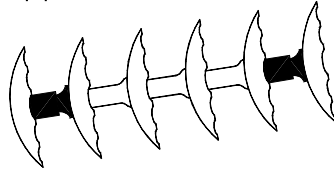
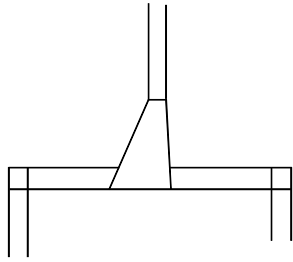

9017 GASPM-HD and  
10020 GASPM-EHD 12 discs  
04 bearings + 06 spacers

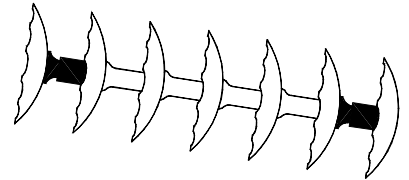
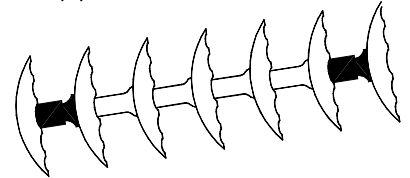
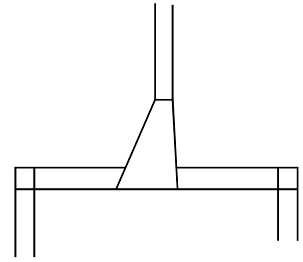

8013 GAPM-HD 14 discs  
04 bearings + 08 spacers

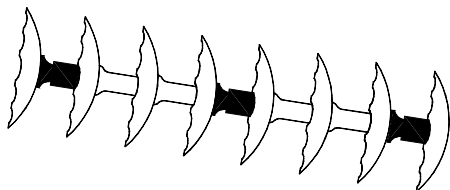
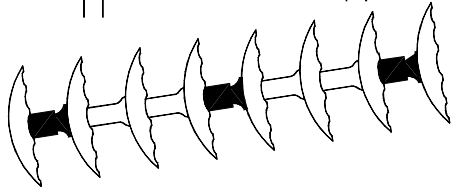
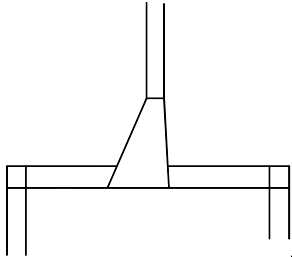

8013 GAPM-HD 16 discs  
06 bearings + 08 spacers

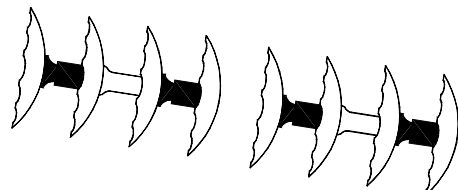
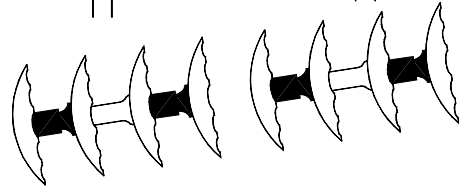
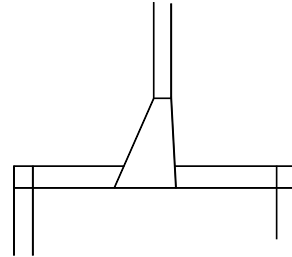

9017 GASPM-HD and  
10020 GASPM-EHD 16 discs  
08 bearings + 04 spacers

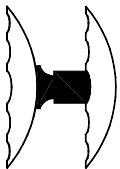

Bearings

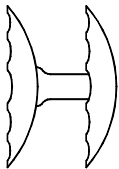

Spacers

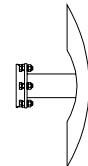

Furrow Filler  
(Optional)

# PREPARATION FOR USE

## Illustration to Assemble Bearings and Spacers

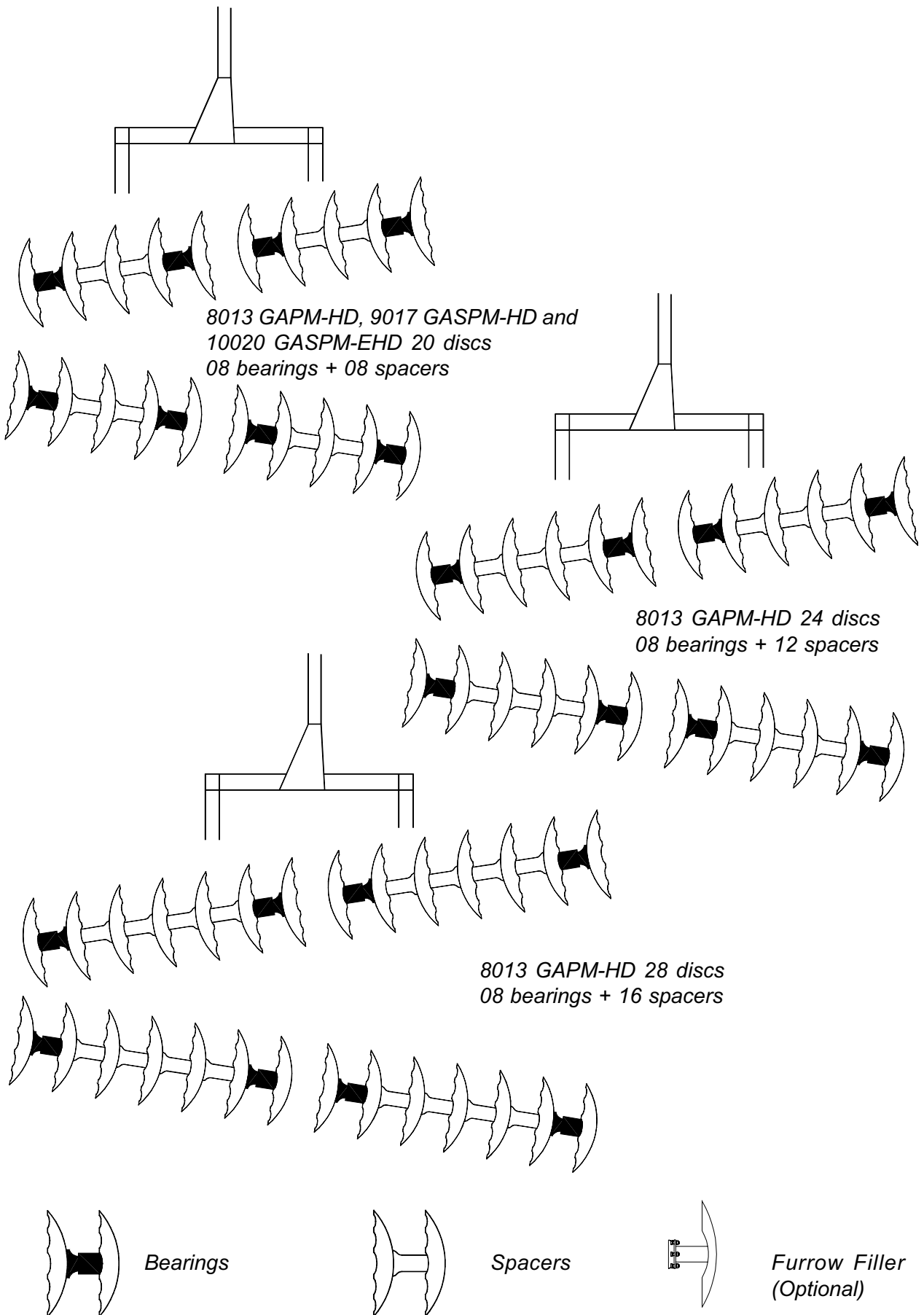



# PREPARATION FOR USE

## DISC GANGS ASSEMBLY

**REFERS TO THE ILLUSTRATION OF THE NEXT PAGE**

- Place the outer lock (A) to the axle (B).
- Screw the nut (C) until passing 5 mm of the axle extremity.
- Install the discs (D), bearings (E) and the spacers (F), following the illustrations from the pages 14 and 15.

**Important:** - BEARINGS AND SPACERS HAVE CONCAVE AND CONVEX ENDS. CURVATURES MUST MATCH WITH DISCS. OTHERWISE GANGS WILL NOT STAY TIGHT AND MAY CAUSE DAMAGE.



- CONCAVE AND CONVEX FLANGES ON THE BEARING ASSEMBLIES ARE FACTORY MOUNTED TO CORRESPOND TO THE FRONT AND REAR GANGS IN ORDER TO HAVE OIL FILL PLUGS OR GREASE FITTINGS ALWAYS FACING TO THE REAR.

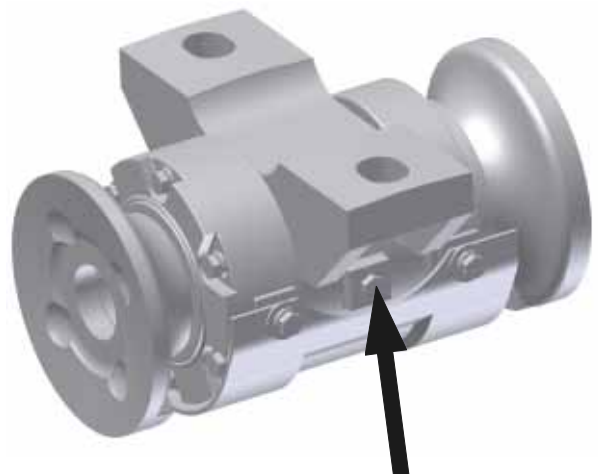

**GREASE FITTING OR PLUG BACKWARDS.**

- Now install the inner lock (G) and the other nut (C-1).
- Install the bolts (H) which fix the nut lock (I), along with flatwashers, lockwashers and nuts, only at the convex side.
- Now, using the axle nut wrenches (A), from page 13, tighten the disc gang as follow:

1<sup>o</sup>) Place one wrench on the convex side of the disc gang (locked side), letting the wrench cable on the ground.

2<sup>o</sup>) On the concave side, use the other wrench and tighten the gang beating in the cable of the wrench to get the maximum torque.

3<sup>o</sup>) Observe that for the disc gangs tightening they should be blocked with a piece of wood or other object, to avoid rolling over movement.

- Finally mount the bolts (H-1) and the nut locks (I-1), using the flatwashers and lockwashers.

**Important:** - RETIGHTEN AXLE NUTS AFTER 10 TO 12 HOURS OF OPERATION. THEREAFTER, VISUALLY INSPECT AXLE NUTS DAILY FOR TIGHTNESS AND RETIGHTEN AS NECESSARY TO ENSURE IF PROPER TORQUE REQUIREMENT IS MAINTAINED.





# PREPARATION FOR USE

## MOUNTING OF DISC GANGS ON GANG CARRIERS

**Important:** THE REAR GANG TURNS DIRT TO THE LEFT AND THE FRONT GANG TURNS DIRT TO THE RIGHT.

**Notes:** IN THE CARRIERS GANG ASSEMBLY, THE STANDARDS SHOULD REMAIN FACING THE DISK BLADES CONCAVITY.  
FRONT GANG ASSEMBLIES WITH CONCAVE SIDE OF THE RIGHT, VIEWED FROM THE REAR OF THE HARROW.  
REAR GANG ASSEMBLIES WITH CONCAVE SIDE OF THE LEFT, VIEWED FROM THE REAR OF THE HARROW.

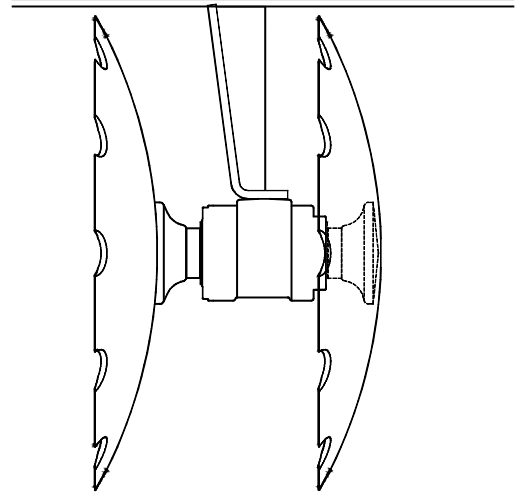

Procedure:

The Illustration below shows the assembly sequence, as follow:

- Fix harrow frame on corresponding gang assemblies and place the bolts (A) and square washers (B) underneath the bearing, so put them through the bearing housing and the standard holes.
- Then, on the top side, place the flat washer (C) and nuts (D).
- Repeat this operation for the other carriers.

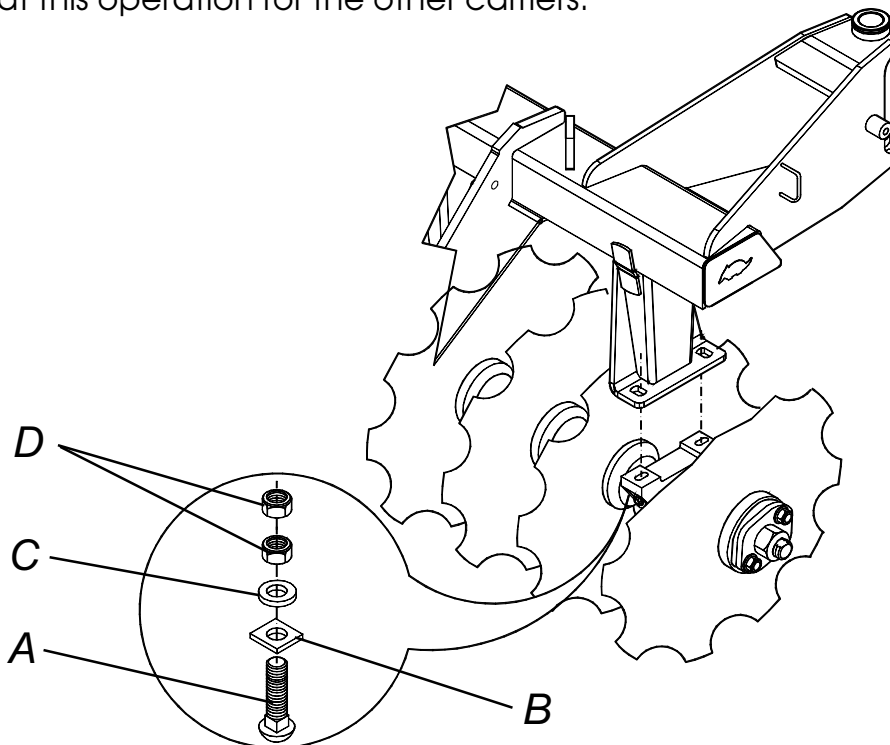

# PREPARATION FOR USE

## GANG CARRIERS JOINT

- Approach the rear gang carrier (A) to the front gang carrier (B), position the hole threaded pin (C) internally both frames assembly.
- Install in the external sides, flat washers (D) along nuts (E) and bolts (F).
- Tighten the bolts (F) on both sides until reach the end of hole threaded pin (C), afterwards lock the flat washers using two nuts (F).

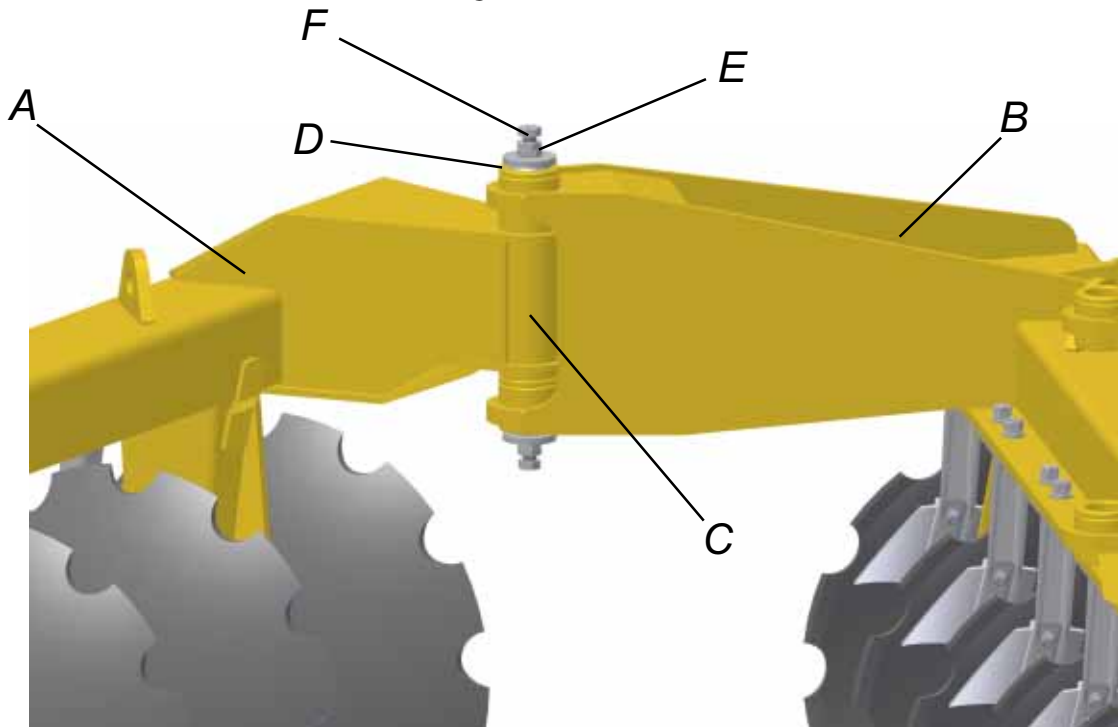

## SCRAPERS ASSEMBLY

- Note the correct scrapers position is the downwardly extremity facing the disc blades concavity.
- Set up the scrapers (A), through the screws (B) and flat washers (C), that are placed underneath the mounting bar. On top side, place the flat washers (C), lock washers (D) and nuts (E).

**Note:** - THE SCRAPERS ARE ADJUSTABLE TO APPROACH OR TO DISTANCE THEM FROM DISC BLADES. IN ORDER TO DISCOURAGE TRASH BUILD-UP BETWEEN DISCS AND SCRAPERS, KEEP THE DISTANCE 3/8" - 3/4" (10 - 20 MM) BETWEEN THEM.

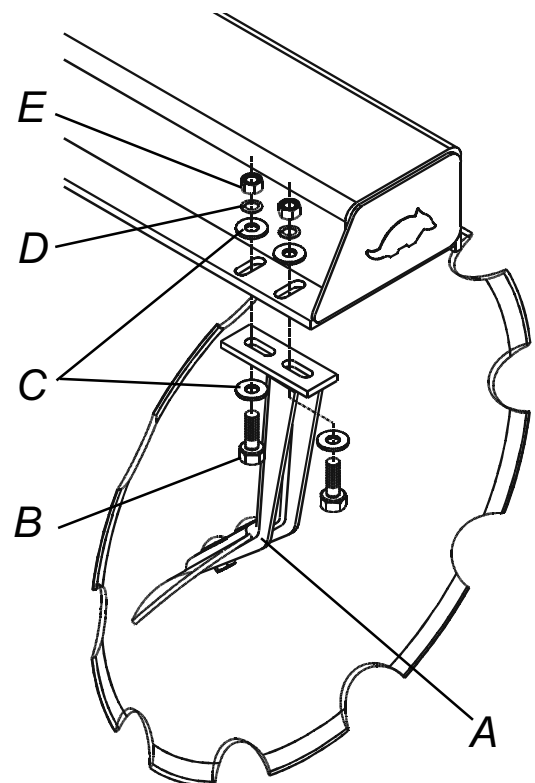

# PREPARATION FOR USE

## WORKING ANGLE ADJUSTING SYSTEM

- Attach the front gang carrier (A) to the front angle adjusting bar (B), positioning the hole threaded pin (C) internally both components.

- Install on both extremities of threaded pin, flat washers (D) along nuts (E) and bolts (F).

- Tighten the bolts (F) on both sides until reach the end of hole threaded pin (C), afterwards lock the flat washers using two nuts (F).

- Afterwards, attach the rear gang carrier (G) to the rear angle adjusting bar (H), positioning the hole threaded pin (C) internally both components.

- Proceed the pin assembly as described for the front gang carrier.

- Then, attach both front and rear angle adjusting bars (I), positioning the hole threaded pin (C) internally both components.

- Proceed the pin assembly as described for the front gang carrier.

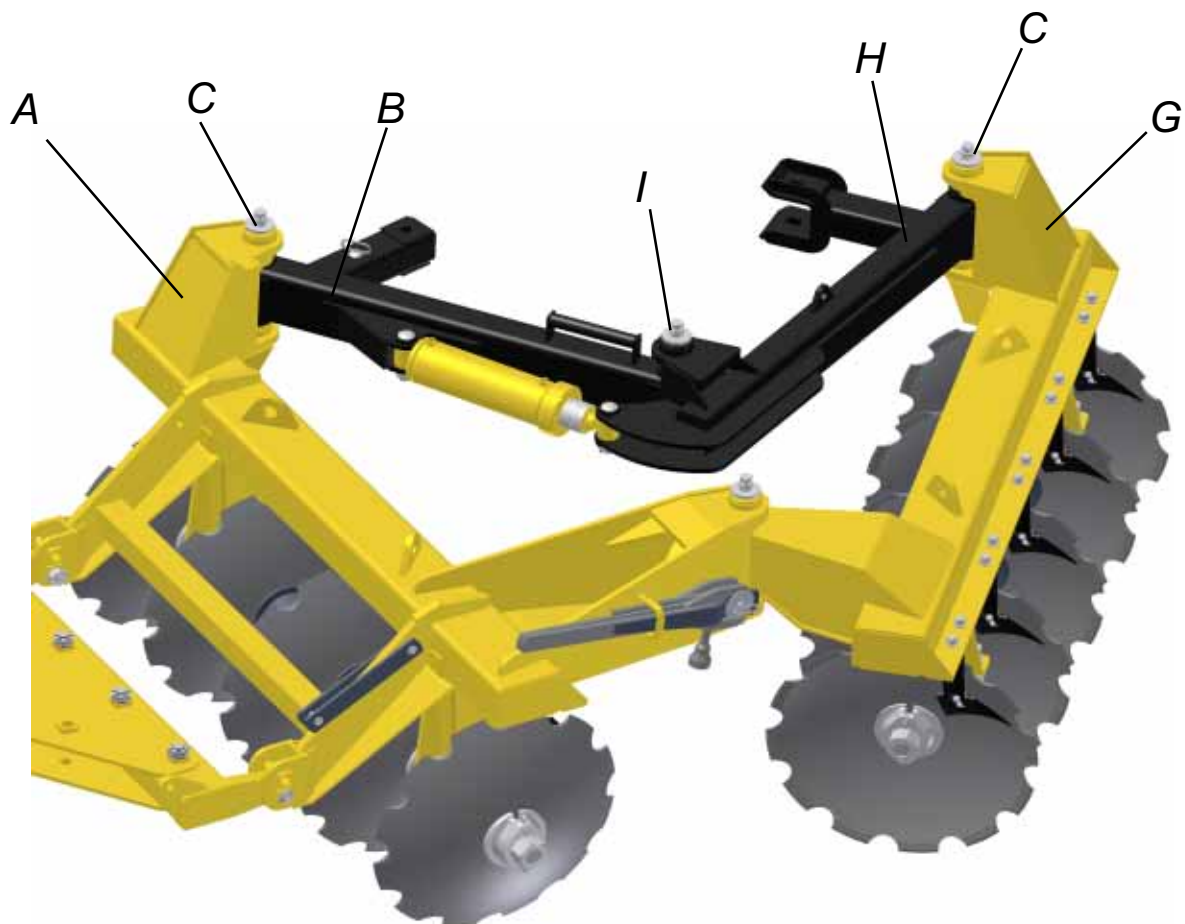
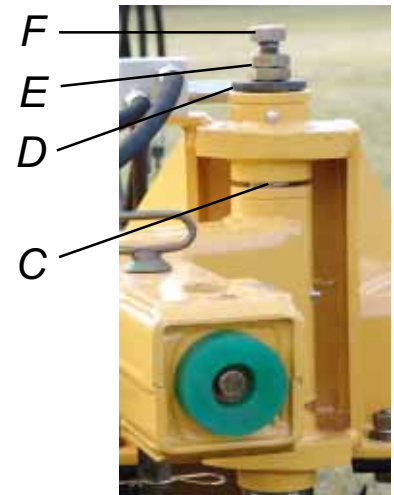

# PREPARATION FOR USE

## HYDRAULIC CYLINDER ASSEMBLY

To assembly the hydraulic cylinder in the harrow, proceed as explained below:

- Mount the hydraulic cylinder (A) in the both front (B) and rear angle adjusting bars (C), using pins (D) and cotter pins.
- Assembly the hose holder (E) in the drawbar using the lock washer and nut.
- Afterwards, attach the hydraulic hoses to the cylinder passing them through the hose holder (E). Note if the quick-couplers are clean and keep them clear the ground.

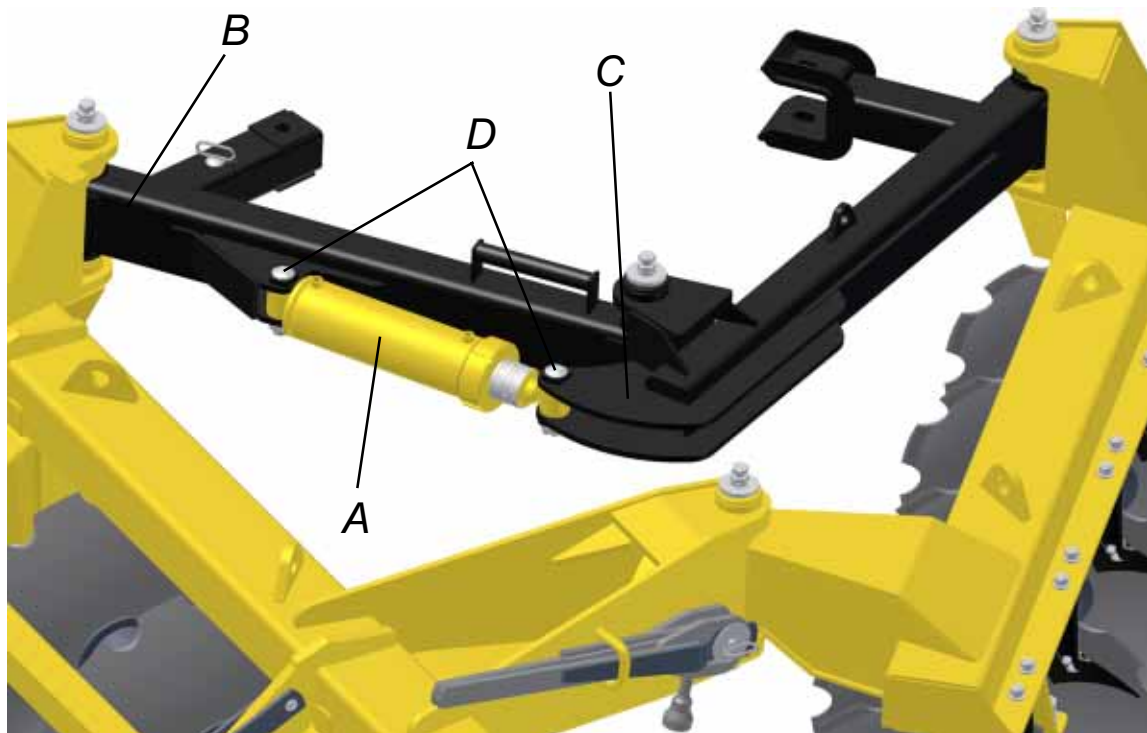

**Note:** - CYLINDER TERMINALS MUST BE ASSEMBLY IN THE UPWARDS POSITION.  
- ALWAYS USE A "SEAL BAND TYPE" WHEN MOUNTING THE QUICK COUPLERS IN THE HYDRAULIC HOSES.

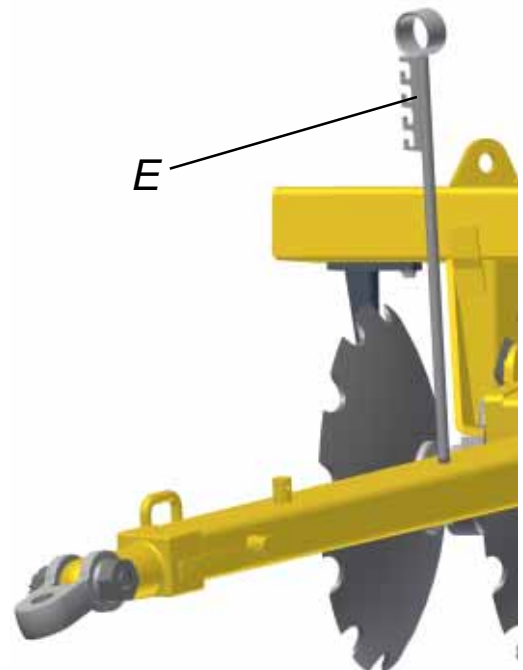

# PREPARATION FOR USE

## MOUNTING THE DRAWBAR ASSEMBLY

- Attach the drawbar (A) in the upper and lower plates (B), then mount the group to the crossbar of the harrow (C) using bolts, lock washers and slotted nuts (D). Check in the illustrations below the correct assembly position of both upper and lower

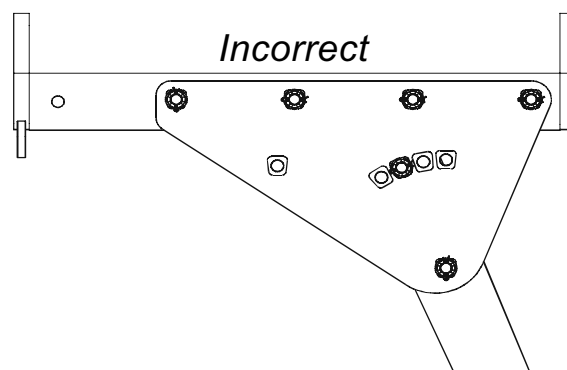
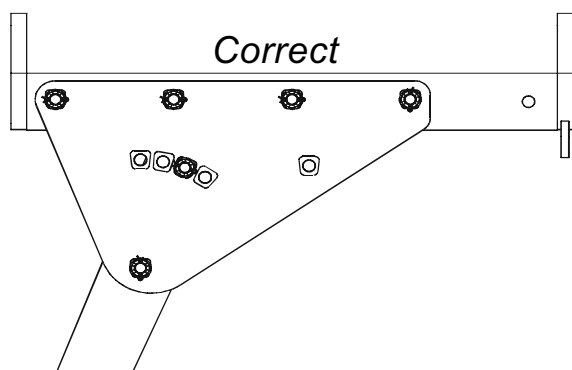
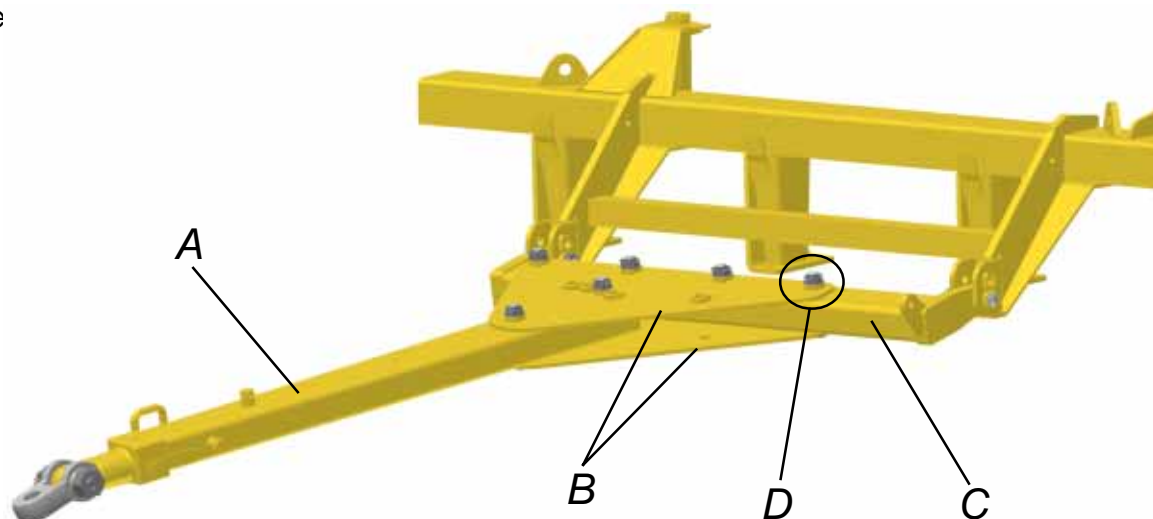

### Safety Chain

When towing implements on a public roadway, use a safety chain (E) with tensile strength equal to or greater than the gross weight of the unit being towed. This will control the implement in the event the hitch pin is lost during transport.

After the ends of the safety chain are attached to the implement and the tractor, make a trial run by driving the tractor to the right and to the left to check for proper length. If necessary, readjust the chain to eliminate loose or tight chain lengths.



**Caution: NEVER USE SAFETY CHAIN FOR TOWING.**

# PREPARATION FOR USE

## MOUNTING THE HYDRAULIC SYSTEM VALVE

Install the flow control valve (A) in the front frame, the valve support is located on the working angle adjustment arm. Note the flow adjusting bolt (B) of the valve is mounted forward the harrow.

Check in the picture the correct position for hydraulic hoses assembly for the flow control valve of the hydraulic cylinder.

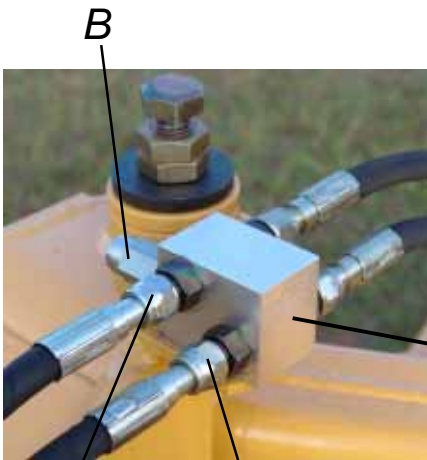

**Position C** - free hydraulic flow to open cylinder.

**Position D** - controlled hydraulic flow to close cylinder, avoiding to squeeze the stoppers.

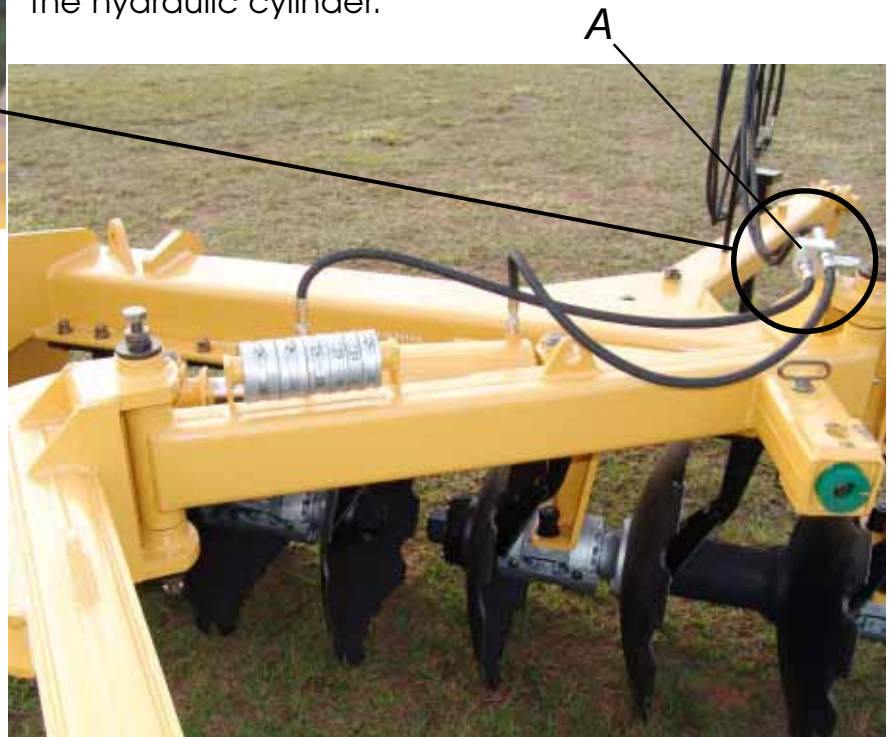

## MOUNTING THE SHOCK ABSORBER

Install the shock absorber (D) in the front frame using flat washer and bolt. This device is useful when the harrow is totally closed in transport position.





# ADJUSTMENT AND OPERATION

## TRACTOR SET-UP

Before starting to operate the harrow, it is necessary to set-up and check adequately the tractor and harrow. Be sure to read and understand all the instructions to obtain best performance on operation and maximum trouble free.

For complete tractor operating instructions, refer to your tractor operator's manual.

For tractor horsepower recommendations, refer to Description and Specifications section for each disc harrow model.

### Tractor Ballast

The addition of water ballast in the tires and extra counterweights in the front or rear tractor wheels are the most useful ways to increase the traction in the soil, getting better stability to the tractor.

### Tractor Wheel Tread

Increase wheel tread to maintain tractor stability when working on inclines or rough ground. Refer to your tractor operator's manual for better instructions.

### Tire Pressure

Inflate tractor tires as recommended by the manufacturer in your tractor operator's manual.

### Tractor Drawbar

The drawbar must be set as indicated on attaching and detaching section. For transporting, pin drawbar to prevent swinging. For operation, it is recommended the swinging position.

### Brakes

Do not transport any equipment unless tractor brakes are in good condition.

To assure adequate braking performance and control during transport, tow only with an agricultural tractor. Safe towing speed depends on weight of tractor and weight of disc harrow and is never greater than 32 km/h (20 mph).

### Hydraulics

A single remote cylinder control valve is required to operate the lift cylinder.

A double remote cylinder control valve is required when the disc harrow is attached to another equipment. It should depend on model or application.



**Caution: NEVER ALLOW RIDERS ON TRACTOR OR DISC.**

# ADJUSTMENT AND OPERATION

## HARROW SET-UP

- Before move the equipment to the field make sure axle nuts are tightened. If they are loose, discs will turn on the axle and the components of the gang will be severely damaged.

- Use a pressure lubrication gun and apply a sufficient amount of grease in all grease fittings. See the instructions on the lubrication section on pages 33 and 34.



**Important: IMPROPER ADJUSTMENTS OF THE EQUIPMENT RESULTS IN RAPID WEAR, POSSIBLE BREAKAGE OF PARTS AND INEFFICIENT OPERATION.**

### Attaching to the Tractor

- Attach the hitch (A) to the tractor and use the appropriate devices to lock it, usually it is done by a pin and cotter-pin. In order to easier handling the hitch, adjust the drawbar height using jackstand (B), acting the lever (C) to lift or lower the drawbar

- Before connect the quick-couplers to the tractor (D), turn off tractor engine, relieve hydraulic pressure and check them for cleanliness or damages.

- After hitching put the jackstand in the transport/working position (E), according to the detail illustrated below.

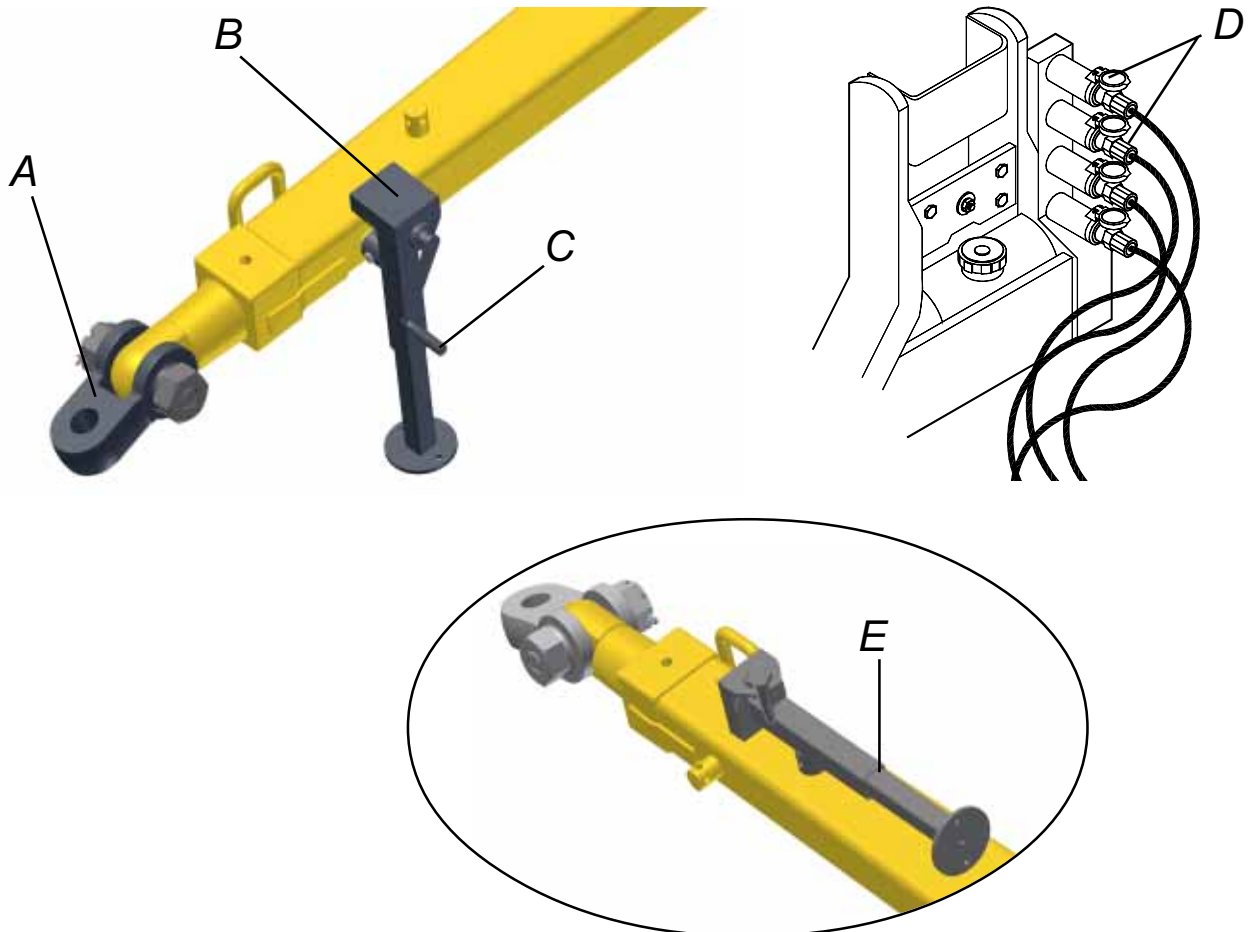

# ADJUSTMENT AND OPERATION

## Harrow Transportation Instructions

- In order to transport the harrow it is necessary to close the angle totally (A), in this way the depth of cut will be minimal, avoiding damages to disc blades along the road way.

- Always pin the safety lock system for transport (B). Whenever the pin is not in use, it remains stored in the front arm of the safety lock system.

- Position the drawbar in the first hole (C) on the upper and lower plates, in this way the harrow will be in a straight position in relation to the tractor, with the minimum penetration to the ground.

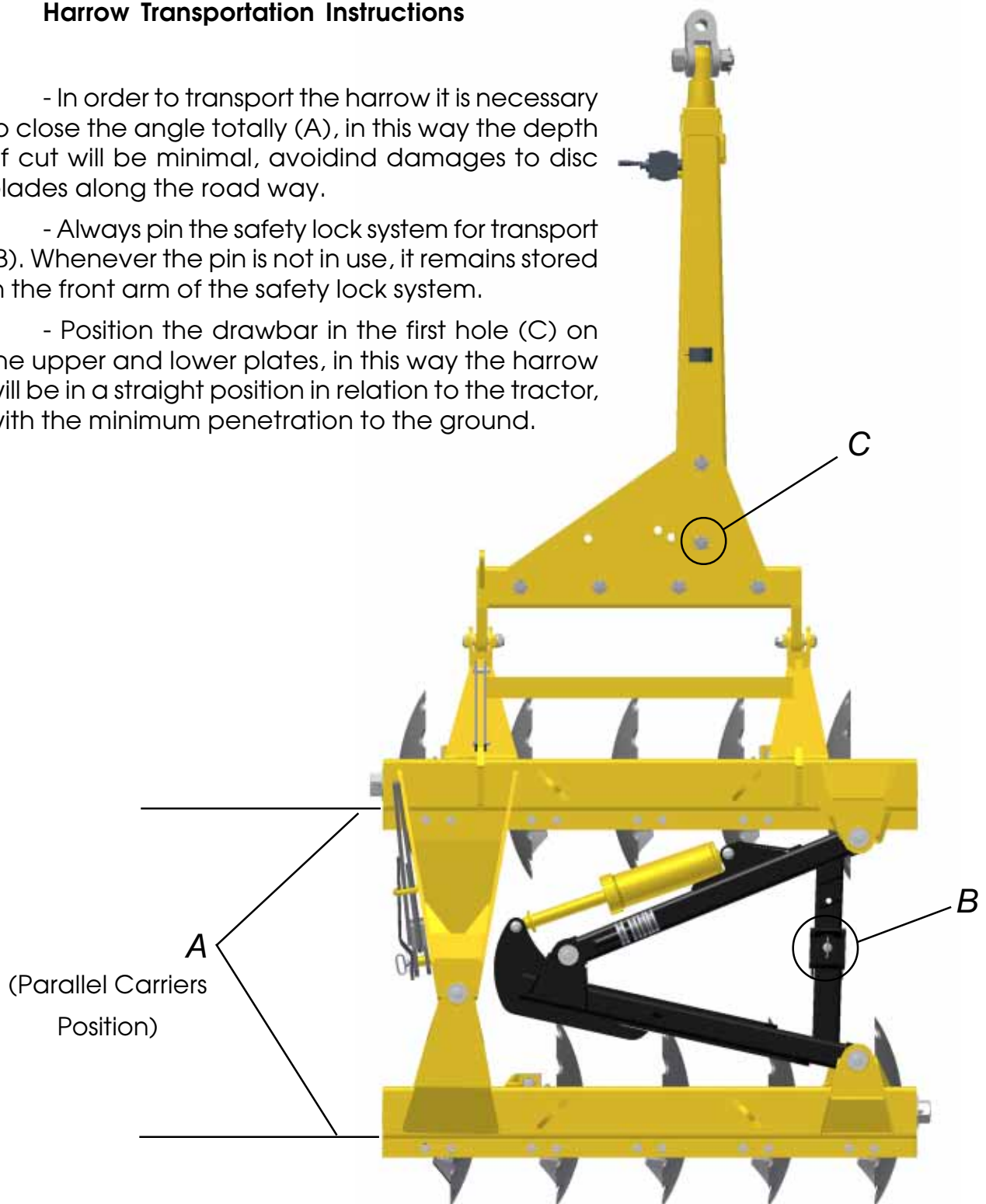

**Caution: ALWAYS PIN THE SAFETY LOCK SYSTEM WHEN TRANSPORTING THE IMPLEMENTS.**

# ADJUSTMENT AND OPERATION

## DEPTH OF CUT

The depth of cut for these models can be done by two ways:

### 1) Angle Adjustment

- Increase the angle (A) between the carriers to work in hard soils, when the penetration to the soil is more difficult. In loose soils, it is recommended to work with smaller angle and less penetration.

- The angle adjustment is made through the cylinder (B). All models are available with stoppers to fix the working angle as necessary.

- Note the rear gang carrier is only one that change position in this adjustment.

- The angle adjustment, opening or closing, must be done gradually with the tractor in movement.

- Adjustable gang axes angle up to 42 degrees.

**Increasing "A":** more soil penetration.

**Decreasing "A":** less soil penetration.

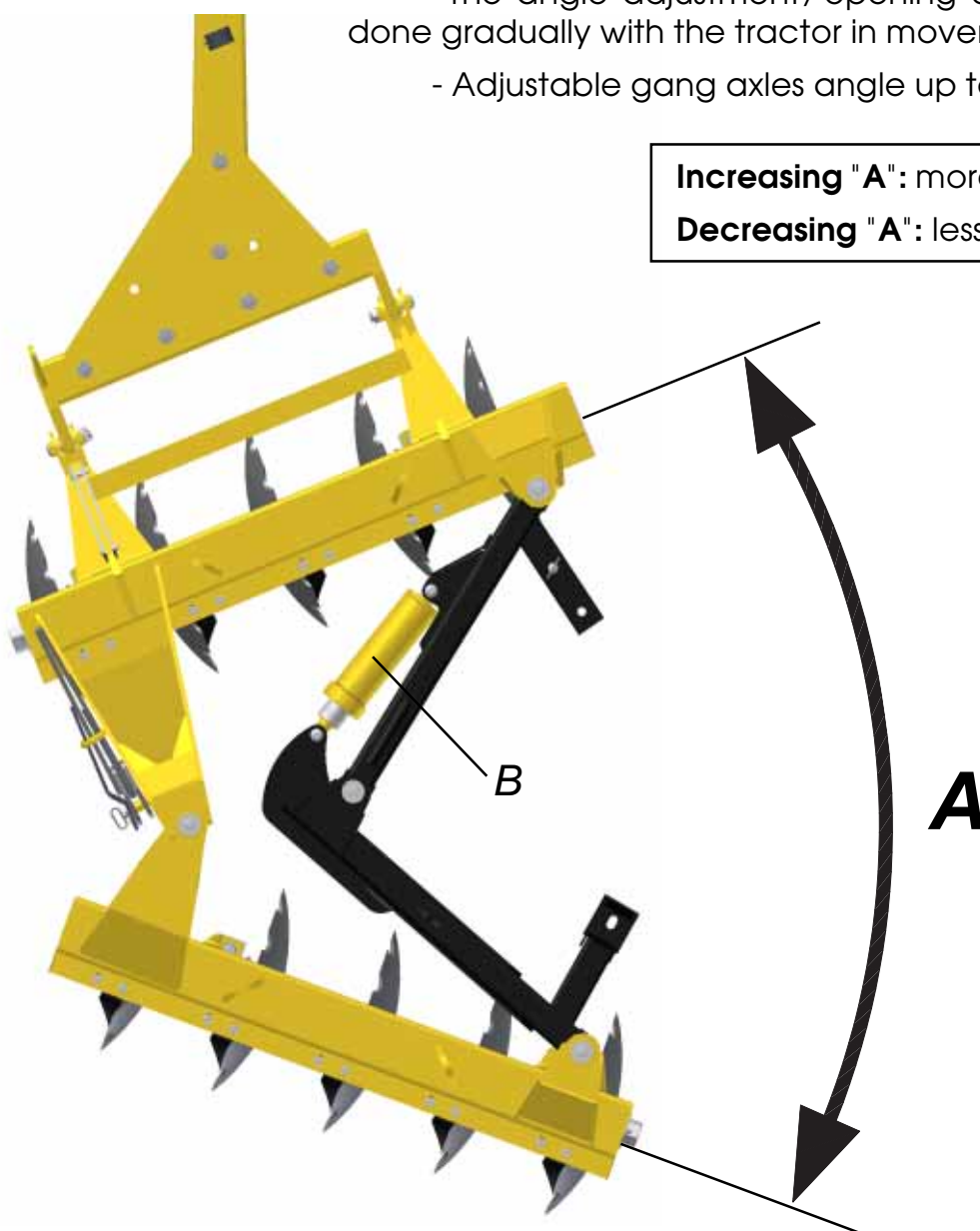

# ADJUSTMENT AND OPERATION

## 2) Drawbar Angle Adjustment

- For medium hardness soil, the drawbar can be utilized in the central position (B) of upper and lower plates.

- The holes in the upper and lower plates are used to change the working angle of the front disc gang carrier.

- The first hole is used for transportation with minimum ground penetration. As soon you change the holes position (form A to D), the ground penetration is increased.

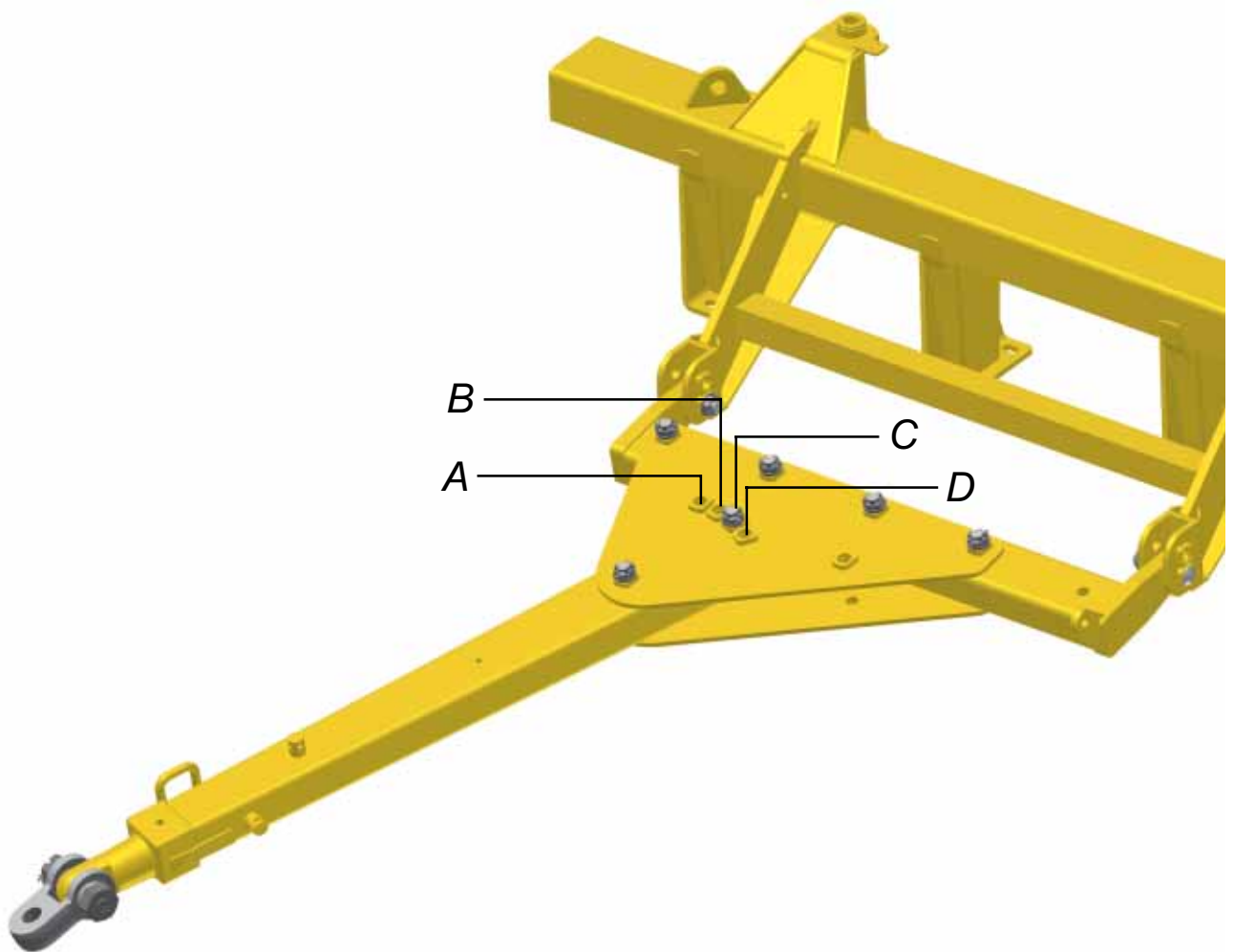

**Attention:** THE ADJUSTMENTS DESCRIBED ABOVE DETERMINE THE DEPTH OF CUT, IT IS NECESSARY TO MAINTAIN A RELATIONSHIP BETWEEN THE ANGLES OF FRONT AND REAR FRAMES TO ALLOW A GOOD HARROW PERFORMANCE.

# ADJUSTMENT AND OPERATION

## DRAWBAR VERTICAL ADJUSTMENT

- The ear frame have two holes for vertical adjustment of drawbar, this assembly is useful for better fit in different tractor models.

- This adjustment also slightly change the depth of cut. Choose the hole that better fit to your tractor drawbar. The upper hole (A) allows a deeper penetration than the lower (B) hole of the ear frame.

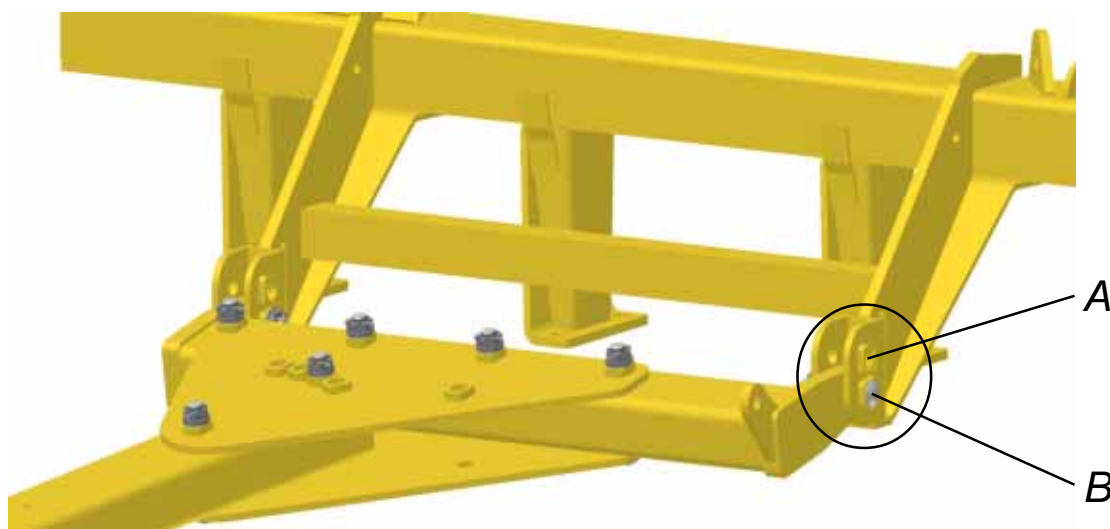

## DRAWBAR LATERAL ADJUSTMENT - OFFSETING

- The lateral adjustment (Offseting) is provide by the hole (C), being a resource useful for better positioning the tractor in relation to the furrow of the previous pass, avoiding to leave track and giving a reference to the operator.

This positioning is obtained in function of tractor tires tread and the harrow width of cut.

Whenever possible, the tractor should move on the untilled soil and near position to the previous furrow.

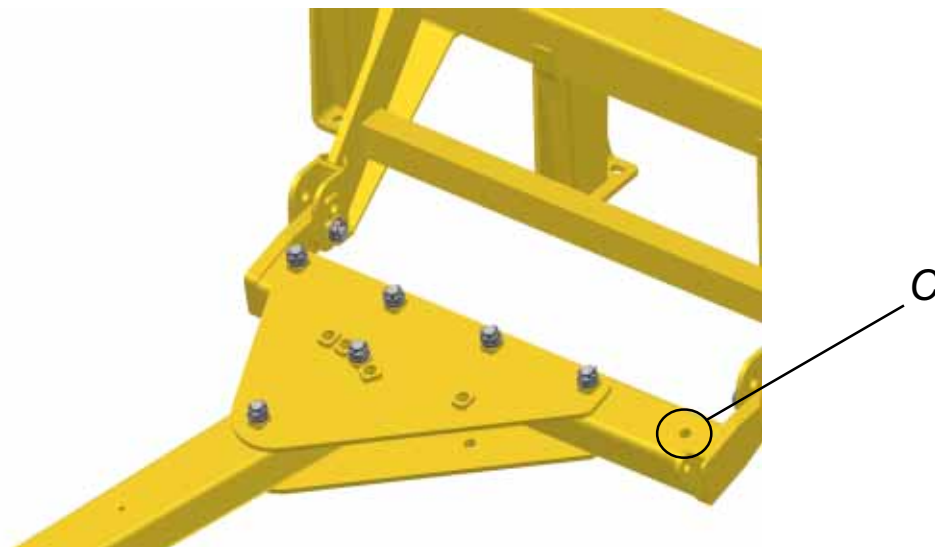

# ADJUSTMENT AND OPERATION

## HOW TO START DISCING

Regardless the area size and boundary level, the discing must be basically made in the following manners: 1) From outside to inside or 2) From inside to outside.

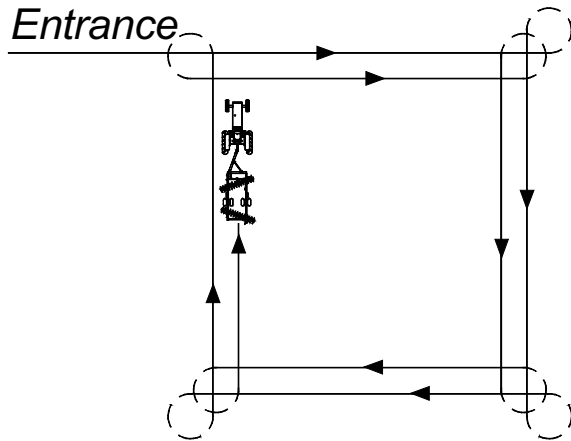

*Discing in Squares from outside to inside.*

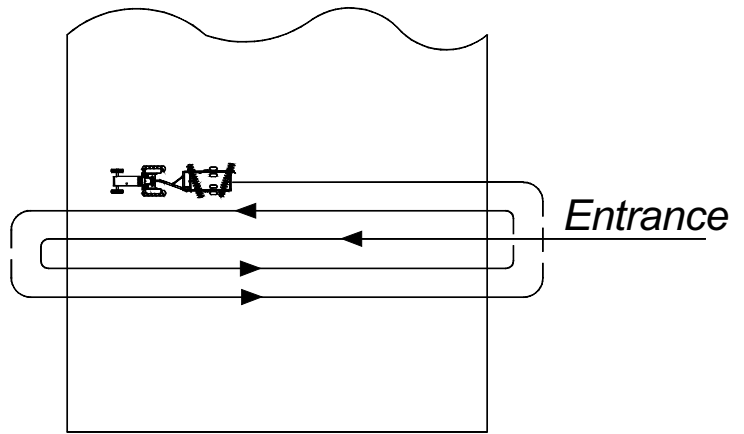

*Discing in Squares from inside to outside.*

## Discing in Level Area

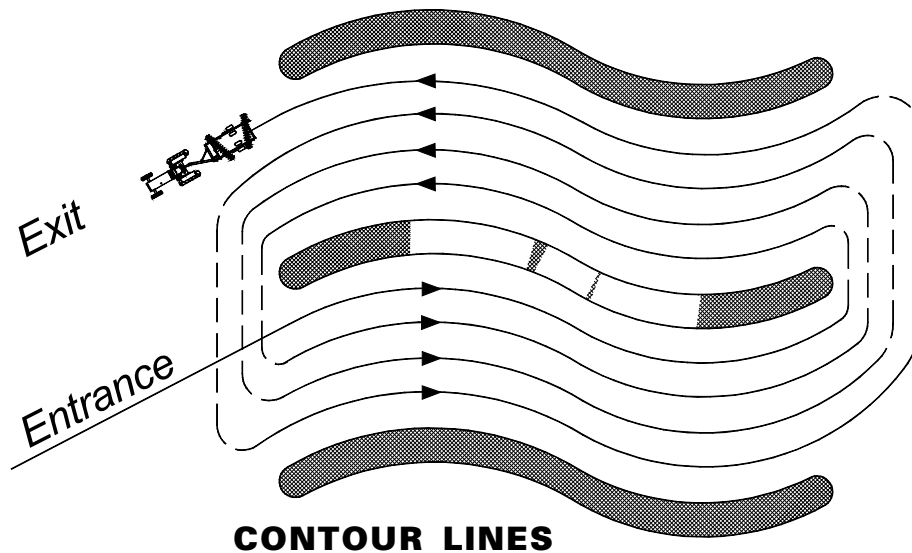

- Important:**
- THE TILLED LAND MUST BE LOCATED ALWAYS ON THE LEFT HAND SIDE OF OPERATOR.
  - WHEN DISCING, RAISE MACHINE OUT OF GROUND BEFORE MAKING TURNS. AVOID MAKING SHARP TURNS THAT MAY CAUSE TRACTOR TIRE TO HAVE CONTACT WITH IMPLEMENT.
  - IF THE FURROW FILLER (OPTIONAL) ATTACHMENT IS USED, IT SHOULD BE RUN ON UNTILLED SOIL.

# ADJUSTMENT AND OPERATION

## MANEUVER DIRECTIONS

The TATU disc harrows, as previously described in the adjustments, allow the set-up of several working angles; to operate appropriately in all kind of soils. However the harrow requires certain cares during operation.

NEVER make maneuvers to the right hand side, because the angle formed by the disc gangs, transmits great effort to the implement, overloading mainly the pulling components, that is, offset bar, drawbar and other fitting parts.

**Attention:** - IT IS NECESSARY TO MAKE THE MANEUVERS TO THE LEFT HAND TO AVOID OVERLOADS TO THE IMPLEMENT AND TO ALLOW ITS NORMAL OPERATION.  
- FOLLOWING THESE INSTRUCTIONS THE FORMATION OF GREAT UNDESIRABLE VALLEYS IN THE MANEUVER AREAS IS AVOIDED.

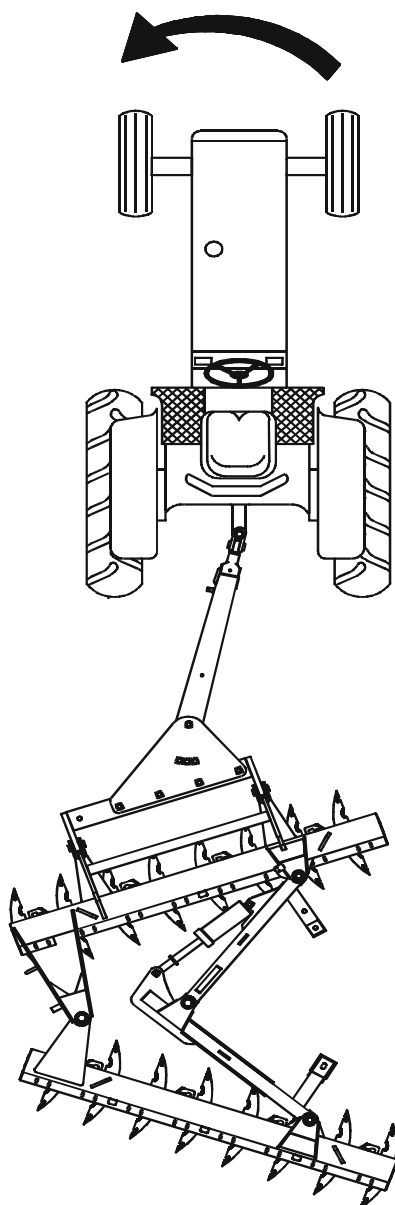



# ADJUSTMENT AND OPERATION

## OPERATION - MAIN INSTRUCTIONS

- Re-tighten nut axles after first day of operation. Thereafter, visually inspect axle nuts daily for tightness and re-tighten as necessary to ensure if the proper torque is maintained.

- Special attention should be paid to the disc gangs, tightening daily during the first week of use. Thereafter, tighten periodically.

- Pay attention to the lubrication intervals.

- Only operate the harrow with a tractor of recommended power.

- The tractor gear to be applied will depend on the soil conditions and plow adjustments, never forget to maintain a power reserve in order to not overload the tractor.

- In order to keep a good operation performance and avoid possible damages to the harrow, it is recommended an average speed of 5.0 to 7.0 km/h (3.1 to 4.4 miles/h).

- When discing, never maneuver to right hand side, the angle formed by the disc gangs transfer much stress to the implement and the consequence will overload all components of the drawbar.

- Remove any wood piece or other object stucked on the disc blades.

- Relieve the control valve pressure before disconnecting the quick couplers and when doing any verification in the hydraulic cylinder.

- As previously mentioned, your TATU disc harrow possess several adjustments for operation, even so, only the local soil conditions can determine their best final adjustments.

- Remove pin from safety lock system in transport position to neutral hole located in front gang carrier before initiate the adjustments.

- When discing, raise machine out of ground before making turns. Avoid to make sharp turns that may cause contact between tires and equipment.

- Disconnect hydraulic hoses from breakaway couplers after release pressure from the system. Plug hoses and place on hose support assembly.

- The tractor drawbar must be fixed in the center position when transporting and loosed when working.

- Be sure tractor and implement have been properly prepared. Operating speed should be between 5,0 to 7,0 km/h. Reduce speed in rocky conditions.

**Attention:**  **DISC BLADES ARE SHARP AND COULD CAUSE INJURIES AS CUT HANDS, FEET, ETC. WEAR GLOVES WHEN HANDLING DISC GANGS TO THE MAIFRAME.**

# MAINTENANCE

## LUBRICATION

### Grease Points

In order to reduce the wearing caused by attrition among moving parts of the machine, it is necessary to make a correct lubrication.

Proceeding a correct lubrication is the simplest way to extend the useful life of your harrow and to avoid working interruptions, as it is described below.

1) At every 24 hours of service, lubricate the articulations through the grease fittings, in the following way:

- Be sure about the lubricant quality, with relation to its efficiency and purity, avoiding the use of products contaminated by water, earth etc.

- Remove the remainder old grease around the articulations.

- Clean the grease fittings with a cloth before insert lubricant and replace the damaged ones.

- Introduce an enough amount of new grease.

2) The lubrication of the greasable roller bearings should be done at the same mentioned period above - 24 hours.

**Note: USE ONLY MEDIUM CONSISTENCY GREASE NLGI GRADE 2-EP MULTI-PURPOSE.**

### Oil Bath Bearings

The oil bath bearings have been filled with lubricant to the proper level prior to shipment. However, you should check the oil level before operating, and frequently thereafter.

1) The oil bath roller bearings work in constant lubrication, but nevertheless it is necessary to give them the following attention:

- In a flat place check the oil level of each bearing, before using the harrow for the first time and everyday of the first week.

- Afterwards, check the oil level weekly.

**Note: THE SUITABLE LEVEL IS WHEN THE OIL REACHES BOTTON OF THE PLUG, BEING THE HARROW IN A FLAT PLACE.**

- Change the whole oil every 1,000 hours of service.

- Use only SAE 90 mineral gear oil.

### Lubricant Storage

Your equipment can operate at top efficiency only when clean lubricants are used. Use clean containers to handle all lubricants.

Whenever possible, store lubricants and containers in an area protected from dust, moisture and other contamination.

Store containers on their side to avoid water and dirt accumulation. Make certain that all containers are properly marked to identify their contents.

Properly dispose of all old containers and any residual lubricant they may contain.

# MAINTENANCE

Lubricate Every 24 Hours of Service



# MAINTENANCE

## LONG TERM STORAGE

Your TATU disc harrow represents an investment from which you should get the greatest possible benefit. Therefore, when the season is over, the harrow should be thoroughly checked and prepared for storage so that a minimum amount of work will be required to put it back into operation for the next season. The following are suggested storage procedures:

- Clean the unit of dirt and trash to minimize rusting and wear.
- Inspect all fasteners for proper torque.
- Inspect all bearings for wear. Replace any worn out bearings.
- Spray the discs with a rust inhibitor or paint to prevent rust. The disc blades should be replaced as soon as they present low output, which is noticed by the decrease of their diameter.
- Clean dirt, oil and grease from areas where paint has been chipped or scratched. Prime bare metal surfaces after cleaning and repaint to prevent rust.
- Replace any decals that are worn or damaged.
- Inspect all movable parts and if any of them is spoiled, replace by new parts available at your TATU dealer.
- Store the harrow in a covered and dry place, avoiding contact of the discs directly with the soil.

### Craning points

The harrow is provided of 4 (four) points for craning (A), these will facilitate the handling of the equipment for storage or transport.

The drawbar should be blocked in the upright position, mounting the locking bar (B) to the ear (C).

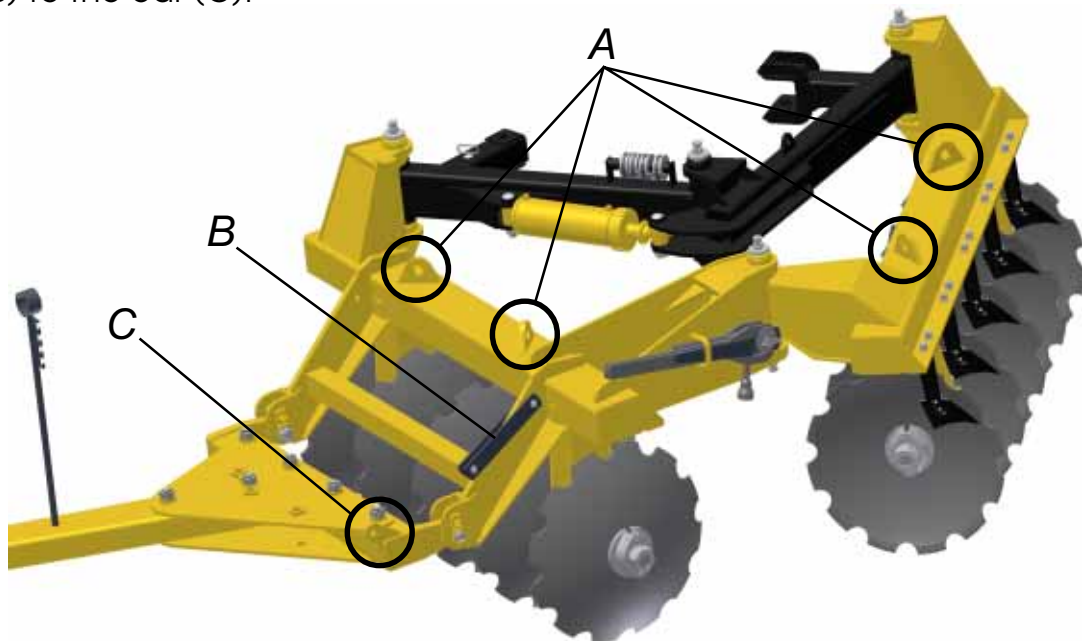

**Caution! ALWAYS BLOCK-UP RAISED EQUIPMENT WHEN SERVICING OR STORAGE . NEVER RELY ON THE HYDRAULIC SYSTEM.**

# IMPORTANT DATA

## HOW TO CALCULATE THEORETICAL HOURLY PERFORMANCE

Use the formula below for performance calculation per hour of your disc harrow.

$$R = \frac{L \times V \times E}{X}$$

Where:

**R** = Performance per hour

**L** = Working width of the harrow, expressed in meters

**V** = Tractor speed average, expressed in meters per hour

**E** = Efficiency (0,90)

**X** = Value of Hectare (10,000 m<sup>2</sup>)

Value of Acre (4,047 m<sup>2</sup>)

### Example of the 9017 GASPM-HD 16 Disc Blades:

**R** = ?

**L** = 3,10 m

**V** = 6,000 m/h

**E** = 0,90

**X** = 10,000 m<sup>2</sup>

$$R = \frac{3,10 \times 6.000 \times 0,90}{10.000}$$

**R** = 1,674 Hectares per Hour.

**R** = 4,136 Acres per Hour.

**Note: EFFECTIVE HARROW PERFORMANCE MIGHT VARY DUE TO PHYSICAL FACTORS AS MOISTURE, DECLIVITY AND HARDPAN. ALSO, THE IMPROPER ADJUSTMENTS AND WORKING SPEED COULD RESULT IN A POOR PERFORMANCE.**

Based on the calculation above it is simple to elaborate the tables on the next page to show theoretical average performance per hour and day (considering 9 hours period).

# IMPORTANT DATA

## THEORETICAL AVERAGE PERFORMANCE TABLE

### 8013 GAPM-HD

Model	No. of Discs	Working Width (m)	Performance per Hour		Performance per Day (09 h)	
			Hectares	(Acres)	Hectares	(Acres)
<b>8013 GAPM-HD</b>	14	2,210	1,193	(2,948)	10,740	(26,539)
	16	2,550	1,377	(3,402)	12,393	(30,622)
	20	3,230	1,744	(4,309)	15,697	(38,788)
	24	3,910	2,111	(5,217)	19,002	(46,954)
	28	4,580	2,473	(6,111)	22,258	(55,000)

### 9017 GASPM-HD

Model	No. of Discs	Working Width (m)	Performance per Hour		Performance per Day (09 h)	
			Hectares	(Acres)	Hectares	(Acres)
<b>9017 GASPM HD</b>	10	1,800	0,972	(2,401)	8,748	(21,616)
	12	2,200	1,188	(2,935)	10,692	(26,419)
	16	3,100	1,674	(4,136)	15,066	(37,227)
	20	4,000	2,160	(5,337)	19,440	(48,035)

### 10020 GASPM-EHD

Model	No. of Discs	Working Width (m)	Performance per Hour		Performance per Day (09 h)	
			Hectares	(Acres)	Hectares	(Acres)
<b>10020 GASPM EHD</b>	10	2,400	1,296	(3,202)	11,664	(28,821)
	12	2,900	1,566	(3,869)	14,094	(34,825)
	16	3,800	2,052	(5,070)	18,468	(45,633)
	20	4,500	2,430	(6,004)	21,870	(54,040)

**Note: IN THE TABLE ABOVE AN AVERAGE SPEED OF 6 KM/H (3,73 MILES/H) WAS USED FOR WORKING PERFORMANCE.**

If you have a certain area and want to know how many hours it will take to work the same, it is enough divide the value of the area by the harrow performance per hour.

Example: An area of 65 Hectares to be worked with a harrow model 9017GASPM HD 16 - Disc Blades (Performance per Hour = 1,674 ha or 4,136 acres).

$$\text{Then: } \frac{65}{1,674} = 38,82$$

It will take approximately 38,82 Hours to work 65 hectares (160.6 acres).

# IMPORTANT

## ATTENTION

MARCHESAN S/A RESERVES THE RIGHT AT ANY TIME TO MAKE IMPROVEMENTS IN THE DESIGN, MATERIAL OR SPECIFICATIONS OF MACHINERY, EQUIPMENT OR PARTS WITHOUT THEREBY BECOMING LIABLE TO MAKE SIMILAR CHANGES IN MACHINERY, EQUIPMENT OR PARTS PREVIOUSLY SOLD.

BECAUSE OF THE POSSIBILITY THAT SOME DRAWINGS OR PICTURES IN THIS MANUAL WERE TAKEN OF PROTOTYPE MODELS, PRODUCTION MODELS MAY VARY IN SOME DETAIL.

SOME PICTURES OF THIS MANUAL APPEAR WITHOUT THE SAFETY DEVICES, TO FACILITATE DETAILED INSTRUCTIONS. NEVER OPERATE EQUIPMENTS WITHOUT THOSE DEVICES.



### **TECHNICAL PUBLICATION DIVISION**

*Elaboration / Diagram: Valson Hernani*

*Translation Supervision: Arnaldo de Aguiar Jr.*

*Illustration: Valdir Silva*

**April, 2006**

**Code: 0501090786**

**Revision: 00**

**MARCHESAN IMPLEMENTOS E MÁQUINAS AGRÍCOLAS TATU S.A.**

Av. Marchesan, 1979 - PO. Box, 131 - CEP 15994-900 - MATÃO - SP - BRASIL

**Tel:** 55 (16) 3382-8282 - **Fax:** 55 (16) 3382-1003 - 55 (16) 3382-1009

e.mail:tatu@marchesan.com.br

<http://www.marchesan.com.br>